

Description

The #6551-99298 Spacer Washer Insertion Tool permits easy installation of spacer washers in bus bar assemblies where multiple bus bars are spaced to provide ventilation for cooling. For proper connection of cable terminals, a spacer washer must be inserted between the bus bars at every terminal bolt position that is in use. This is necessary to provide a low resistance current path and maintain correct space between the bus bars for proper cooling.

Operating Instructions

1. As shown below, the spacer washer is inserted in the tool and held with a firm grip of the hand.
2. The tool is used to slide the spacer washer between the bus bars so the terminal bolt can be installed through the hole in the bus bar and the hole in the spacer washer.
3. This procedure is repeated until a spacer washer has been installed at every terminal bolt location.

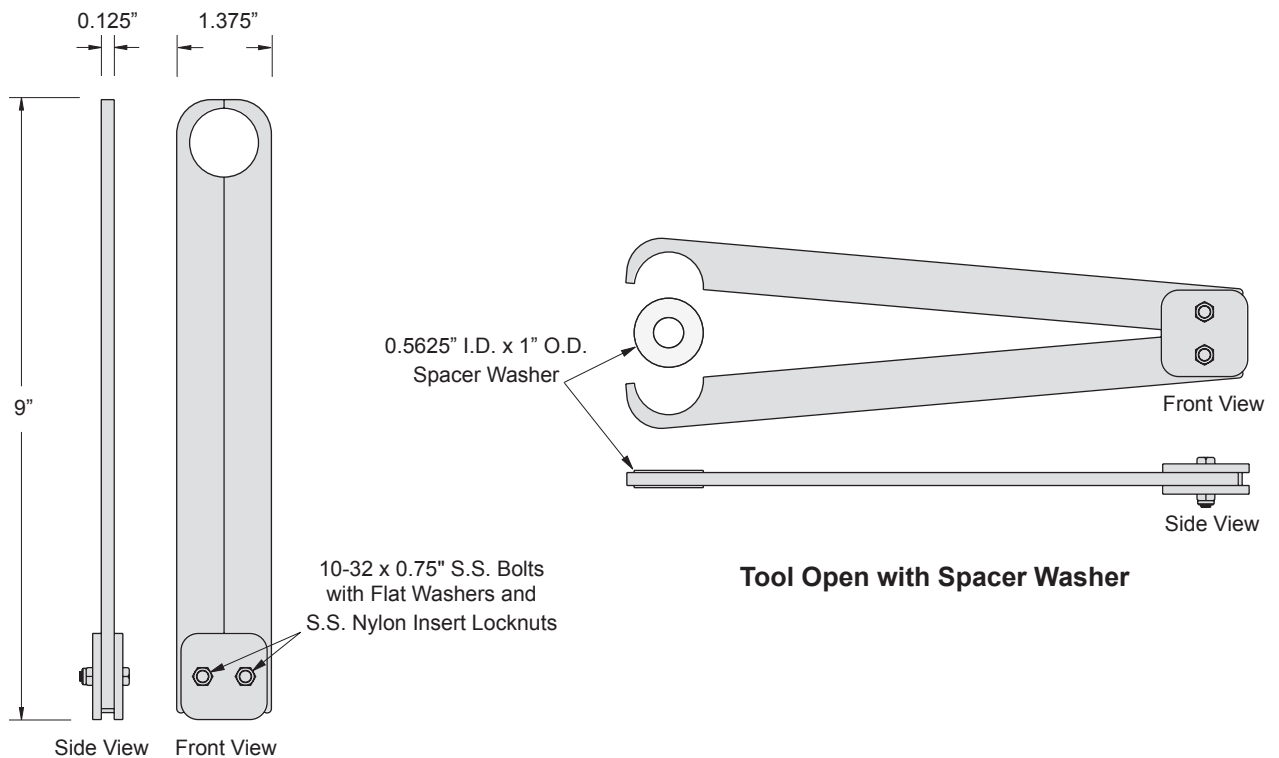

Tool Closed

Tool Open with Spacer Washer

Catalog No.	Description
6551-99298	0.5625" ID x 1" OD x 0.25" Bus Bar Spacer Washer Insertion Tool



Bus Bar Spacer Washer Insertion Tool

Descriptive
Bulletin

6551

Page 2 2009

If you do not find the design
you need

PLEASE CONTACT

our REPRESENTATIVE or the FACTORY