

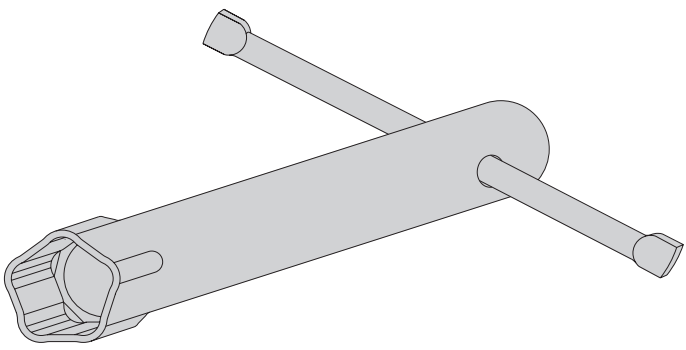

Penta Wrench

Descriptive Bulletin
6201
 Page 1 2009

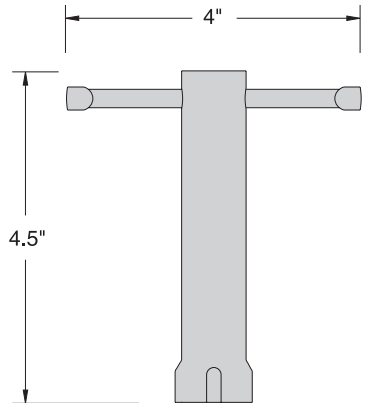

Penta

Hex

Catalog No.	Description	Material
6201-PW10	"T" Type Penta Wrench	0.0625 Wall Light Galv. Mild Steel with 0.25" Dia. Stainless Steel T-Handle
6201-HW10	"T" Type Hex Wrench	0.0625 Wall Light Galv. Mild Steel with 0.25" Dia. Stainless Steel T-Handle

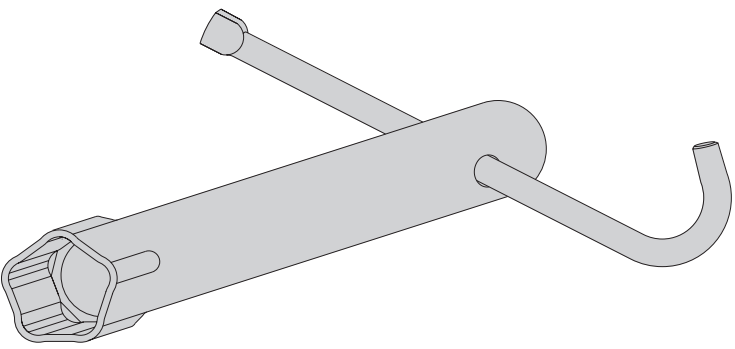
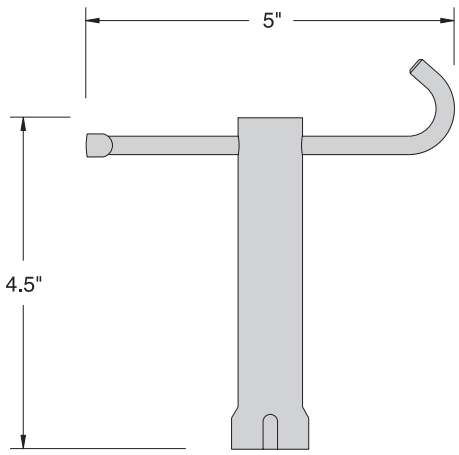

Penta

Catalog No.	Description	Material
6201-PW15	"T" Type Penta Wrench with Lift Hook	0.0625 Wall Light Galv. Mild Steel with 0.25" Dia. Stainless Steel T-Handle



Penta Wrench

Descriptive
Bulletin
6201
Page 2 2009

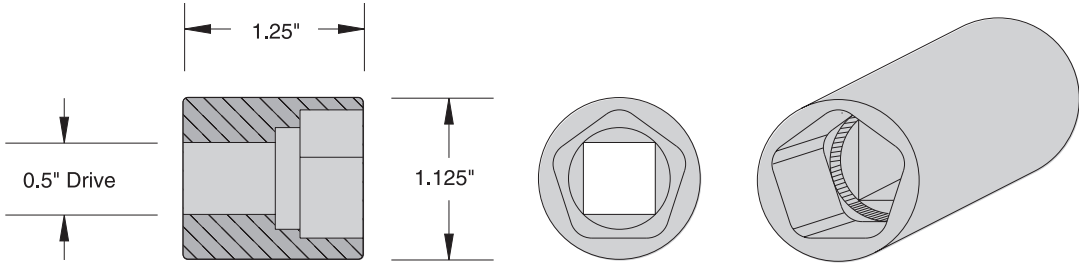

Catalog No.	Description	Material
6201-PW20	Penta Socket	High Carbon Alloy Steel Nickel Chromed Plated