

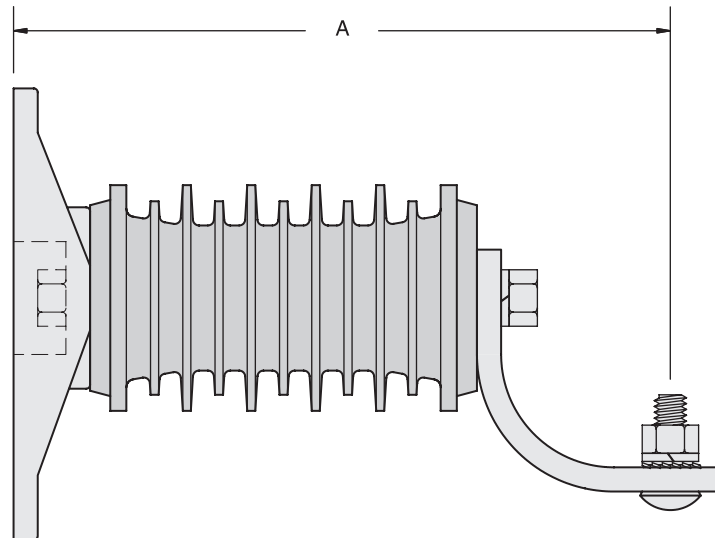

Insulator/Bracket Assembly

Indoor - Outdoor
Single Bolt Series 0.5" - 13 Inserts

Descriptive
Bulletin
2901-001
Page 1 2009

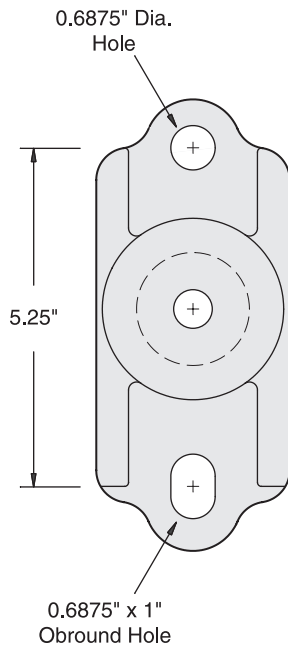

ELRIM Cycloaliphatic Epoxy Provides:

- Nontracking, self-scouring, nonweathering performance
- Superior dielectric strength, dielectric loss and power factor
- Choice of shapes allows design innovation
- Mechanical and thermal toughness
- Shatter-free arc flashover performance
- Oil resistant

Elliott Design Provides:

- Cast-in-place inserts without metal end caps
- Contamination resistant Elliott square-edge skirts
- Generous dry arcing (strike) distance
- Increased leakage distance to resist contamination
- Thermal cycling withstand from +200° F to -200° F
- High strength - field proven performance
- Experience with cycloaliphatic epoxy since 1975

Insulator/Bracket assemblies include a base that can be bolted to a pole or back-to-back to a crossarm and an "L" bracket that can support arresters, fuse cutouts or other apparatus. These assemblies have been used to provide extra strike and leakage distance for arresters and cutouts operating in salt-contaminated conditions where similar porcelain insulators were not satisfactory. The unique Elliott square-edge skirt design and the superior qualities of cycloaliphatic epoxy give these insulator/bracket assemblies unusually high performance in severely contaminated environments.

Ratings and Dimensions of Insulator/Bracket Assembly

Assembly Catalog Number	Insulator Catalog Number	Nominal Voltage kV	Withstand Test Voltage Kilovolts			"A" Inches	Minimum Leakage Inches	Minimum Strike Inches
			Impulse 1.2 x 50	One Min. Dry.	10 Sec. Dew			
2901-BLI-3.5	2101-103.5-0.5	5	60	26	26	7.63	6	3.5
2901-BLI-6	2101-106-0.5	15	95	50	50	10.13	14.5	6
2901-BLI-7.5	2101-107.5-0.5	25	125	60	60	11.63	18	7.5
2901-BLI-8.5	2101-108.5-0.5	25	125	70	70	12.63	21	8.5
2901-BLI-10	2101-110-0.5	35	150	80	80	14.13	26.5	10
2901-BLI-12.5	2101-112.5-0.5	35	200	100	100	16.63	33	12.5

Insulator/Bracket Assembly

Indoor - Outdoor
Single Bolt Series 0.5" - 13 Inserts

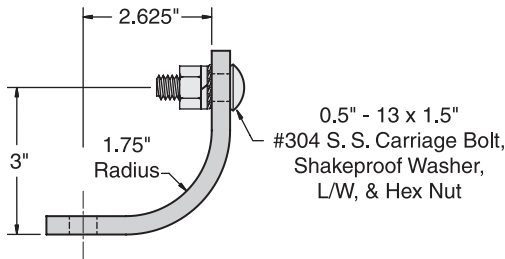

#2909-L81142 Angle Detail
0.375" x 1.5" #6061T6 Aluminum

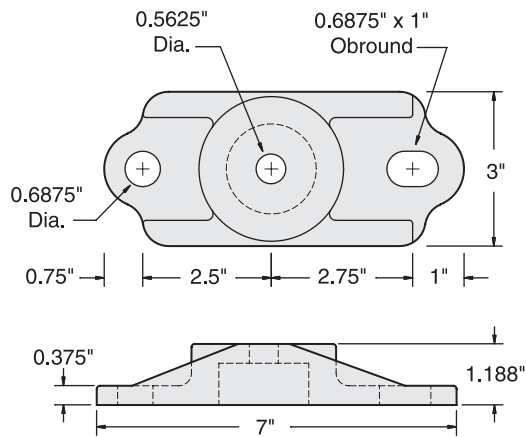

#2909-B84175 Base Detail
Tenzaloy Aluminum

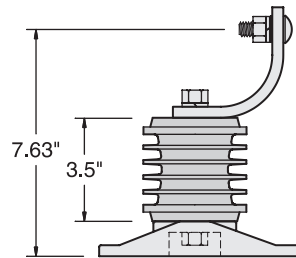

#2901-BLI-3.5

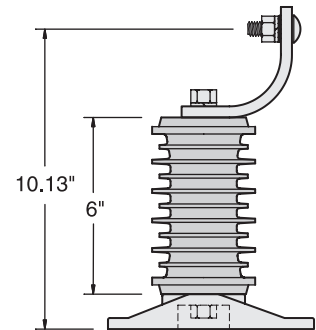

#2901-BLI-6

Catalog Number	2901-BLI-3.5	2901-BLI-6
Electrical Rating, kV		
Nominal Voltage	5	15
BIL	60	95
A.C. Withstand - 1 Min. Dry	26	50
A.C. Withstand - 10 Sec. Dew	26	50
Leakage Distance, Inches	6	14.5
Dry Arcing Distance, Inches	3.5	6
Angle, Mechanical-Strength Rating, Pounds		
Yield, Ultimate	800	800
Base, Mechanical-Strength Rating, Pounds		
Cantilever, Ultimate 3 inches above top*	Exceeds Insulator Mechanical Strength	Exceeds Insulator Mechanical Strength
Mechanical-Strength Rating, Pounds		
Cantilever, Ultimate 2.5 inches above top*	1,500	900
Tensile, Pounds	4,000	4,000
Torsion, Inch-Pounds	1,000	1,000
Compression, Pounds	20,000	20,000
Insert Thread Size (Top / Bottom)	0.5" - 13	0.5" - 13
Net Weight, Pounds (kg)	3.5 (1.59)	4.25 (1.93)

* To attain their rated cantilever strengths, insulators must be mounted on a flat surface that is at least as wide as the diameter of the base of the insulator. Furthermore, the mounting surface must be free of protrusions, such as lumps from galvanizing, to prevent cracking of the insulator when mounting bolts are tightened.

Insulator/Bracket Assembly

Indoor - Outdoor
Single Bolt Series 0.5" - 13 Inserts

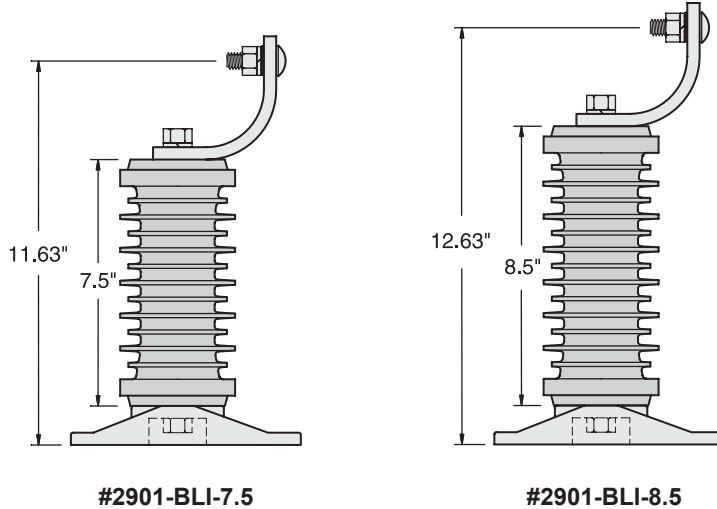

Catalog Number	2901-BLI-7.5	2901-BLI-8.5
Electrical Rating, kV		
Nominal Voltage	25	25
BIL	125	125
A.C. Withstand - 1 Min. Dry	60	70
A.C. Withstand - 10 Sec. Dew	60	70
Leakage Distance, Inches	18	21
Dry Arcing Distance, Inches	7.5	8.5
Angle, Mechanical-Strength Rating, Pounds		
Yield, Ultimate	800	800
Base, Mechanical-Strength Rating, Pounds		
Cantilever, Ultimate 3 inches above top*	Exceeds Insulator Mechanical Strength	Exceeds Insulator Mechanical Strength
Mechanical-Strength Rating, Pounds		
Cantilever, Ultimate 2.5 inches above top*	800	750
Tensile, Pounds	4,000	4,000
Torsion, Inch-Pounds	1,000	1,000
Compression, Pounds	20,000	20,000
Insert Thread Size (Top / Bottom)	0.5" - 13	0.5" - 13
Net Weight, Pounds (kg)	5.0 (2.27)	5.25 (2.38)

Insulator/Bracket Assembly

Indoor - Outdoor
Single Bolt Series 0.5" - 13 Inserts

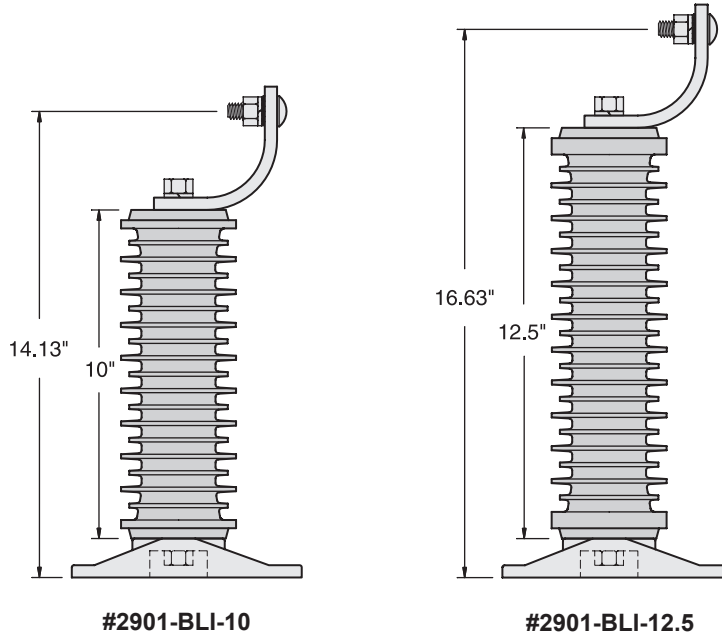

Catalog Number	2901-BLI-10	2901-BLI-12.5
Electrical Rating, kV		
Nominal Voltage	35	35
BIL	150	200
A.C. Withstand - 1 Min. Dry	80	100
A.C. Withstand - 10 Sec. Dew	80	100
Leakage Distance, Inches	26.5	33
Dry Arcing Distance, Inches	10	12.5
Angle, Mechanical-Strength Rating, Pounds		
Yield, Ultimate	800	800
Base, Mechanical-Strength Rating, Pounds		
Cantilever, Ultimate 3 inches above top*	Exceeds Insulator Mechanical Strength	Exceeds Insulator Mechanical Strength
Mechanical-Strength Rating, Pounds		
Cantilever, Ultimate 2.5 inches above top*	600	400
Tensile, Pounds	4,000	4,000
Torsion, Inch-Pounds	1,000	1,000
Compression, Pounds	20,000	20,000
Insert Thread Size (Top / Bottom)	0.5" - 13	0.5" - 13
Net Weight, Pounds (kg)	5.75 (2.61)	6.45 (2.93)