

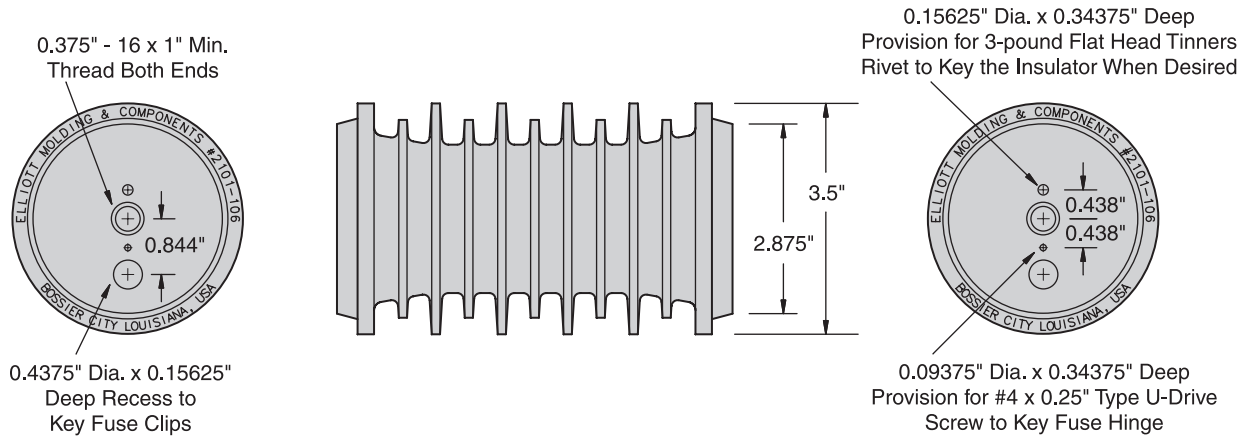

Apparatus Insulators

Indoor - Outdoor
Single Bolt Series 0.375" - 16 Inserts

Descriptive
Bulletin
2101-001
Page 1 2008



ELRIM Cycloaliphatic Epoxy Provides:

- Nontracking, self-scouring, nonweathering performance
- Superior dielectric strength, dielectric loss and power factor
- Choice of shapes allows design innovation
- Mechanical and thermal toughness
- Shatter-free arc flashover performance
- Oil resistant

Elliott Design Provides:

- Cast-in-place inserts without metal end caps
- Contamination resistant Elliott square-edge skirts
- Generous dry arcing (strike) distance
- Increased leakage distance to resist contamination
- Thermal cycling withstand from +200° F to -200° F
- High strength - field proven performance
- Experience with cycloaliphatic epoxy since 1975

The insulators described in this bulletin have special features to provide superior mechanical support and to key fuse clips, fuse hinges, buswork and other high-voltage apparatus.

- 1) McGraw-Edison NX[®] fuse clips mount with a 0.375" - 16 thread bolt and are automatically keyed by an existing rivet on the fuse clip which insets in the 0.4375" diameter x 0.156" deep recess.
- 2) McGraw-Edison NX[®] fuse hinges mount with a 0.375" - 16 thread bolt and key on a #4 x 0.25" type U-drive screw installed in the 0.09375" diameter x 0.34375" deep recess.
- 3) To mount the insulator, when no adjustment is required, a 0.4375" diameter mounting hole accommodates the 0.375" - 16 thread mounting bolt.
- 4) To mount the insulator, when ± 0.0625" adjustment is required, a 0.4375" x 0.5625" obround slot is required.
- 5) To mount and key the insulator, when no adjustment is required, a 0.4375" x 0.8125" obround slot will accommodate the 0.375" - 16 thread mounting bolt and a 3-pound flat head tinners rivet installed in the 0.15625" diameter x 0.34375" deep recess.
- 6) To mount and key the insulator, when ± 0.1562" adjustment is required, a 0.4375" x 1.125" obround slot will accommodate the 0.375" - 16 thread mounting bolt and a 3-pound flat head tinners rivet installed in the 0.15625" diameter x 0.34375" deep recess.

Ratings and Dimensions of Apparatus Insulators

Catalog Number	Nominal Voltage kV	Withstand Test Voltage Kilovolts			Height Inches	Minimum Leakage Inches	Minimum Strike Inches
		Impulse 1.2 x 50	One Min. Dry.	10 Sec. Dew			
2101-103.5	5	60	26	26	3.5	6	3.5
2101-106	15	95	50	50	6	14.5	6
2101-107.5	25	125	60	60	7.5	18	7.5
2101-108.5	25	125	70	70	8.5	21	8.5
2101-110	35	150	80	80	10	26.5	10
2101-112.5	35	200	100	100	12.5	33	12.5

NX[®] is a registered trademark of Cooper Power Systems



Apparatus Insulators

Indoor - Outdoor
Single Bolt Series 0.375" - 16 Inserts

Descriptive
Bulletin
2101-001
Page 2 2008

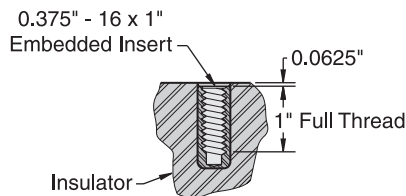
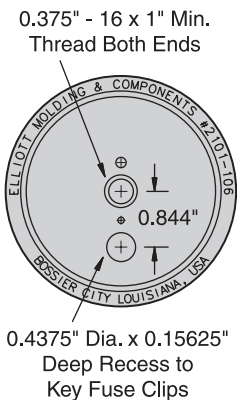

0.15625" Dia. x 0.34375" Deep
Provision for 3-pound Flat Head
Tinner's Rivet to Key the Insulator
When Desired

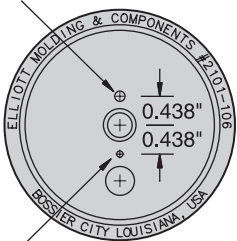

0.09375" Dia. x 0.34375" Deep
Provision for #4 x 0.25" Type U-Drive
Screw to Key Fuse Hinge

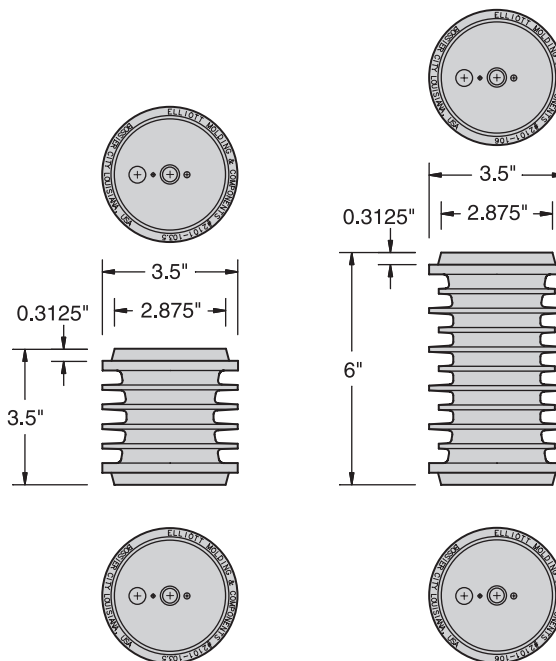

#2101-103.5

#2101-106

Catalog Number	2101-103.5	2101-106
Electrical Rating, kV		
Nominal Voltage	5	15
BIL	60	95
A.C. Withstand - 1 Min. Dry	26	50
A.C. Withstand - 10 Sec. Dew	26	50
Leakage Distance, Inches	6	14.5
Dry Arcing Distance, Inches	3.5	6
Mechanical-Strength Rating, Pounds		
Cantilever, Ultimate 2.5 inches above top*	1,000	550
Tensile, Pounds	3,000	3,000
Torsion, Inches-Pounds	1,500	1,500
Compression, Pounds	20,000	20,000
Insert Thread Size	0.375" - 16	0.375" - 16
Net Weight, Pounds (kg)	1.7 (0.77)	2.4 (1.1)

* To attain their rated cantilever strengths, insulators must be mounted on a flat surface that is at least as wide as the diameter of the base of the insulator. Furthermore, the mounting surface must be free of protrusions, such as lumps from galvanizing, to prevent cracking of the insulator when mounting bolts are tightened.

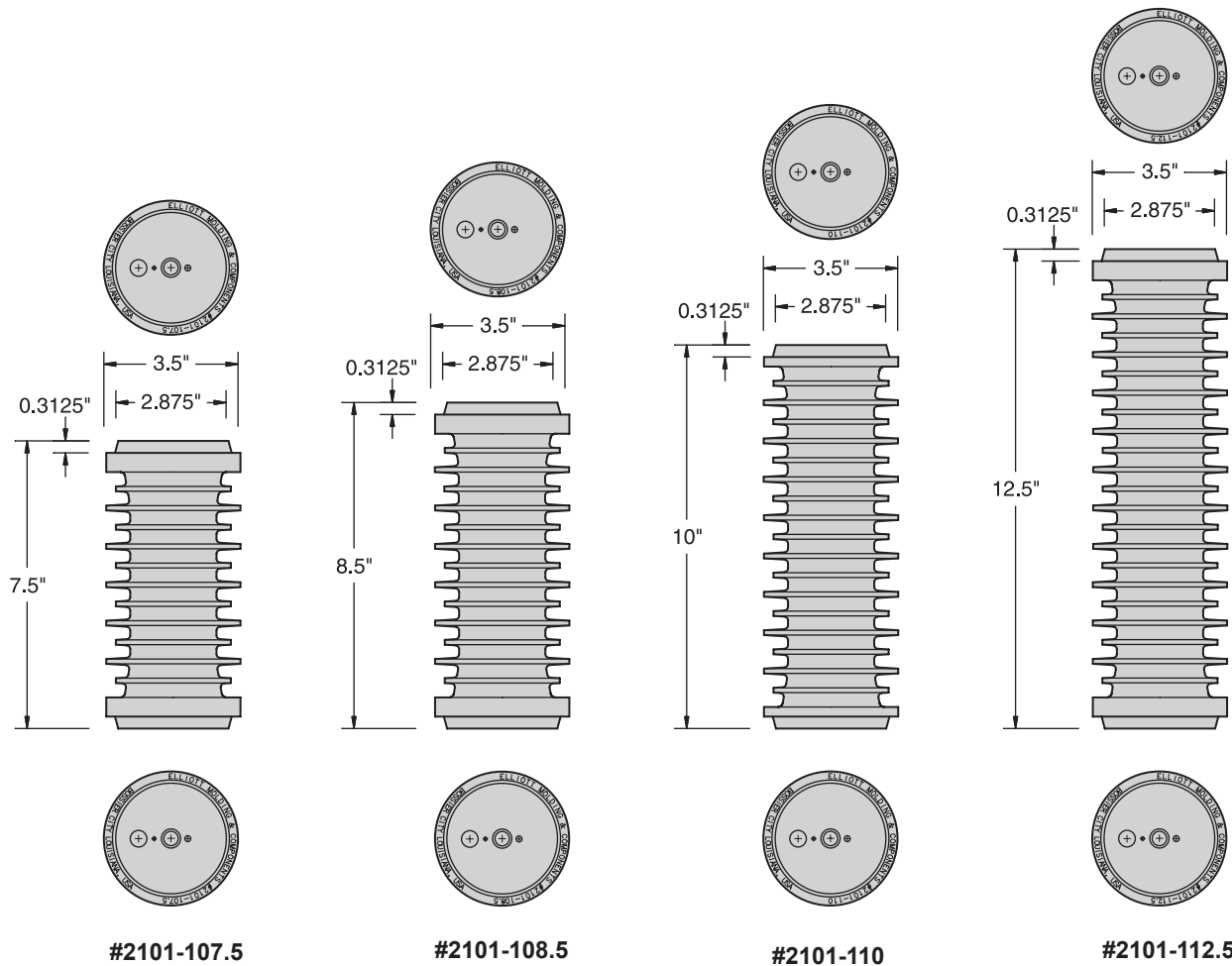

#2101-107.5

#2101-108.5

#2101-110

#2101-112.5

Catalog Number	2101-107.5	2101-108.5	2101-110	2101-112.5
Electrical Rating, kV				
Nominal Voltage	25	25	35	35
BIL	125	125	150	200
A.C. Withstand - 1 Min. Dry	60	70	80	100
A.C. Withstand - 10 Sec. Dew	60	70	80	100
Leakage Distance, Inches	18	21	26.5	33
Dry Arcing Distance, Inches	7.5	8.5	10	12.5
Mechanical-Strength Rating, Pounds				
Cantilever, Ultimate 2.5 inches above top*	450	300	250	200
Tensile, Pounds	3,000	3,000	3,000	3,000
Torsion, Inches-Pounds	1,500	1,500	1,500	1,500
Compression, Pounds	20,000	20,000	20,000	20,000
Insert Thread Size	0.375" - 16	0.375" - 16	0.375" - 16	0.375" - 16
Net Weight, Pounds (kg)	3.1 (1.4)	3.4 (1.6)	3.8 (1.7)	4.4 (2.0)



Apparatus Insulators
Indoor - Outdoor
Single Bolt Series 0.375" - 16 Inserts

Descriptive
Bulletin
2101-001
Page 4 2008

**If you do not find the design
you need**

PLEASE CONTACT

our REPRESENTATIVE or the FACTORY