

Order: #1991-CRAR Clamp Ring Adapter with Hardware

The #1991-CRAR Clamp Ring Adapter permits a #1101-225A2 Elliott Bushing Well to be mounted, with an RTE® Clamp Ring, in equipment originally equipped with the RTE® 8.3 kV Safebreak Bushing. The clamp ring is located on the elbow side of the equipment mounting plate to eliminate the possibility of reduced phase-to-ground clearance. The #1991-CRAR Clamp Ring Adapter comes complete with the bolts, nuts, and washers shown below.

Do not energize this bushing with only the shipping cap in place. To do so would lead to failure of the bushing and create a hazard to operating personnel. *This product is designed to be used only when it is mated with an appropriate 15 kV or 25 kV class bushing insert conforming to the latest revision of IEEE Standard 386.* The bushing insert should be installed in accordance with the instructions supplied by the connector manufacturer.

Installation Instructions

NOTE: The shipping cap should be left in place to prevent contamination of the interface.

1. The bushing well installs from the elbow side for easy installation.
2. The clamp ring adapter and RTE® clamp ring are placed on the bushing.
3. Flat washers, lock washers and nuts are installed on the bolts. The nuts should be tightened in a uniform manner rather than one-by-one in a random sequence. Do not apply more than 90 inch-pounds torque to each nut.

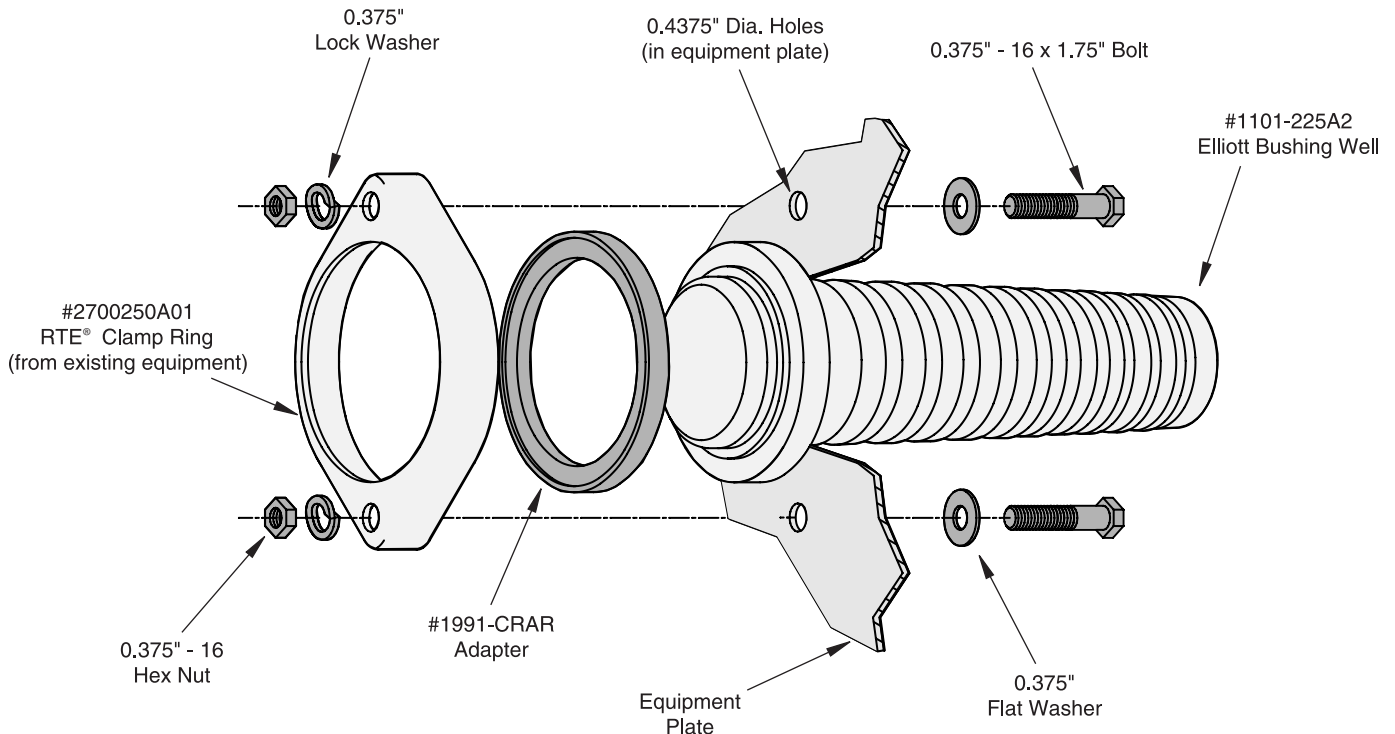

RTE® is a registered trademark of Cooper Industries, Inc.

Clamp Ring Adapter

For Mounting Elliott Bushing Wells with RTE® Clamp Ring

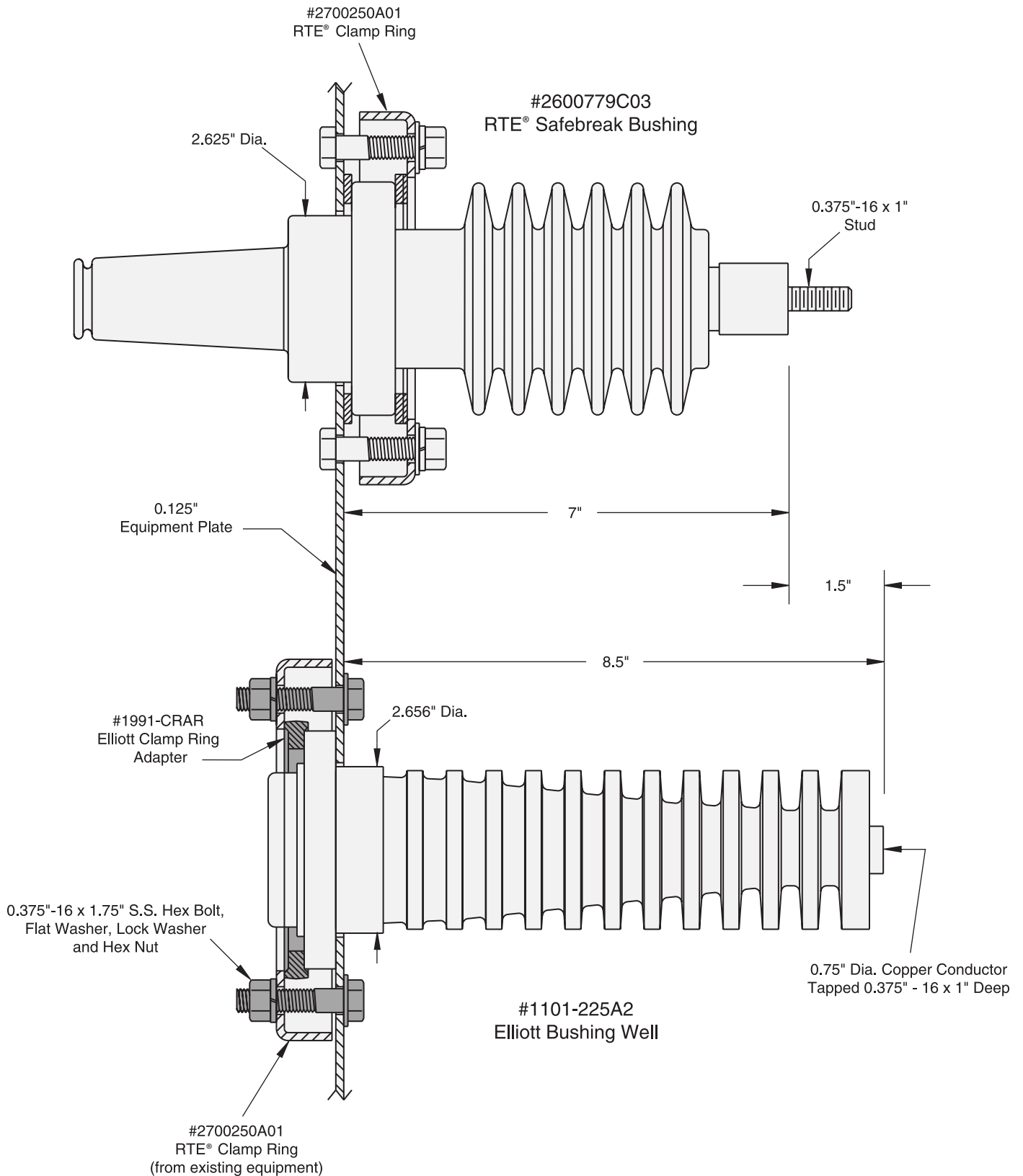

RTE® is a registered trademark of Cooper Industries, Inc.