

# Bushing Mounting Support Plate

For Elliott Air Insulated SuperWells

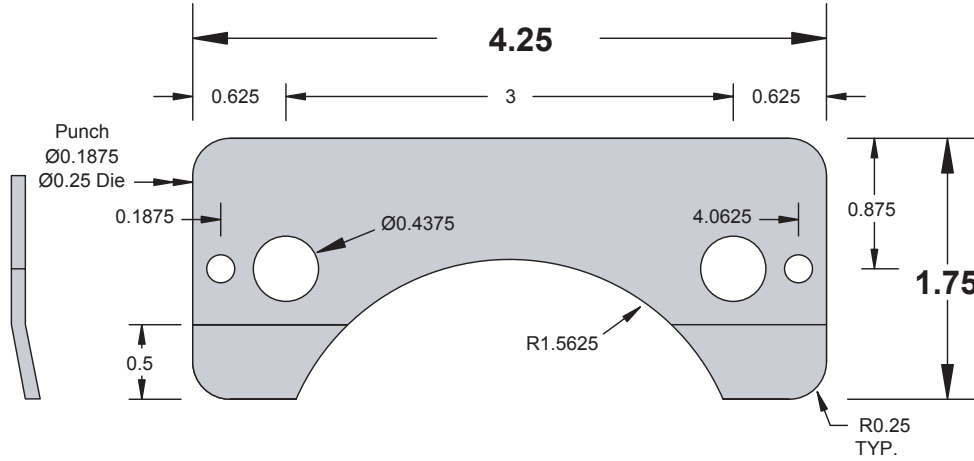

Catalog No.	Description	Material
1908-BMSP	Bushing Mounting Support Plate (with burr to cut thru paint to ground)	12-gauge #304L Stainless Steel

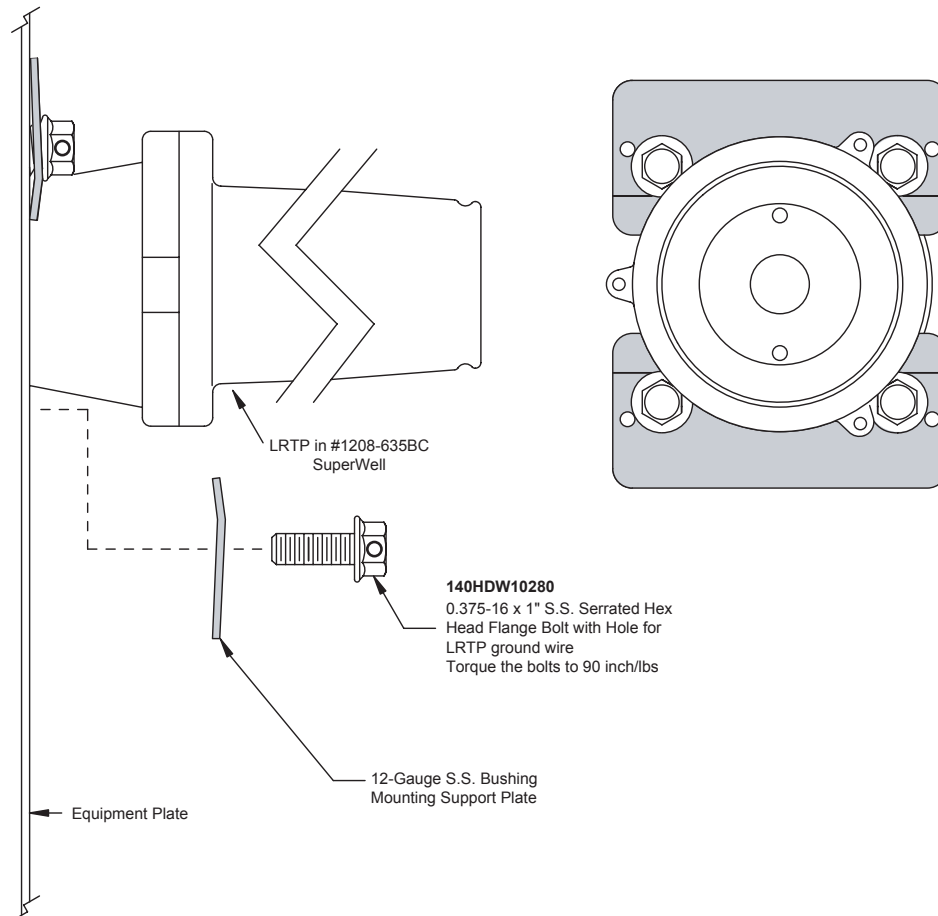



## **Bushing Mounting Support Plate**

For Elliott Air Insulated SuperWells

Descriptive  
Bulletin  
**1908**  
Page 2 2009

**If you do not find the design  
you need**

**PLEASE CONTACT**

**our REPRESENTATIVE or the FACTORY**