

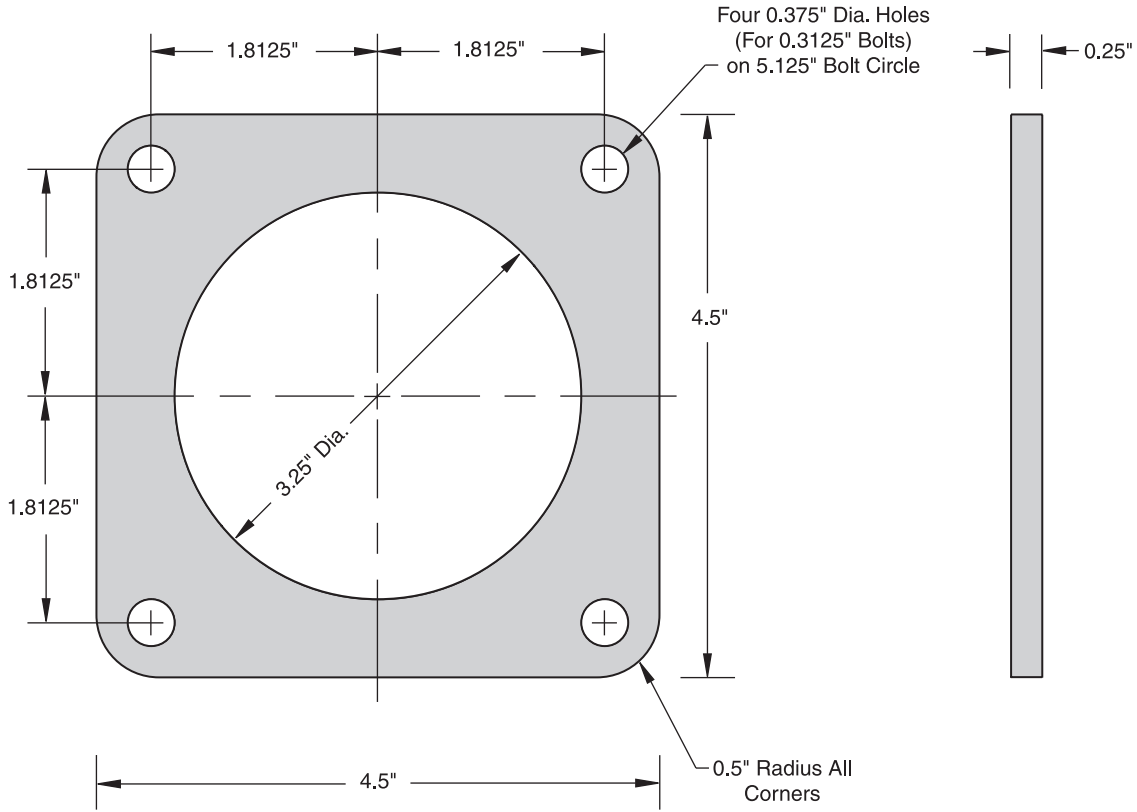

Bushing Clamp Ring

For Elliott Air Insulated Bushings

Descriptive
Bulletin
1902
Page 1 2008



Recommended Mounting:
Four 0.3125" - 18 x 1.25"
Studs on 5.125" Bolt Circle

Catalog No.	Description	Material
1902-CR4S-A2F	Bushing Clamp Ring	0.25" 6061-T6 Aluminum Plate



Bushing Clamp Ring

For Elliott Air Insulated Bushings

Descriptive
Bulletin
1902
Page 2 2008

**If you do not find the design
you need**

PLEASE CONTACT

our REPRESENTATIVE or the FACTORY