

**For 15-kV and 25-kV Connectors (Elbows)
to Oil Insulated Equipment**

The Elliott #1611-625L Bushings are used to construct oil insulated equipment that connects to the utility's underground shielded cable system with IEEE Standard separable insulated connectors (i.e. elbows). The #1611-625L Bushing is designed for use in oil or SF₆ Gas. The interface accepts 600 Amp, 15 kV or 25 kV IEEE Standard separable insulated connectors (i.e. elbows), and provides a removable, shielded connection to shielded cable. Integral shielding prevents "edge-of-hole" corona discharge. The large diameter live end terminal pad (with female threads) provides for direct contact of current-carrying parts and eliminates exposed sharp threads, which could induce destructive corona discharge. In addition to IEEE Standard 386 design tests, Elliott bushings are design tested for thermal cycle withstand from +200° to -200° F to assure long field life. Every bushing is production tested "in air" mounted in a grounded steel plate with an insulated protective plug (or cap) installed on the interface to accurately simulate operating conditions.

ELRIM Cycloaliphatic Epoxy Provides:

- Nontracking, self-scouring, nonweathering performance
- Superior dielectric strength, dielectric loss and power factor
- Choice of shapes allows design innovation
- Mechanical and thermal toughness
- Shatter-free arc flashover performance
- Oil resistant

Elliott Design Provides:

- Precision molded interfaces per IEEE Standard 386
- Integral shielding to prevent destructive corona discharge
- Large diameter live end terminal pad with female threads for direct contact of current-carrying parts and improved corona performance
- Thermal cycle withstand from +200° to -200° F for long life
- High Strength - field proven performance since 1975

Ratings and Dimensions

Catalog Number	S&C Replacement	Voltage Class kV	Continuous Current Amps	Withstand Test Voltage Kilovolts			Minimum Leakage Inches	Minimum Strike Inches
				Impulse 1.2 x 50	One Min. Dry	10 Sec. Dew		
1611-625L Bushing	--	25	600	125	40	N/A	8.5	8.5



25-kV Apparatus Bushing

“L” Series (clamp-in) for Elbow to Oil Insulated Service
600 Amp

Descriptive
Bulletin
1611-600
Page 2 2008

Bushing #1611-625L

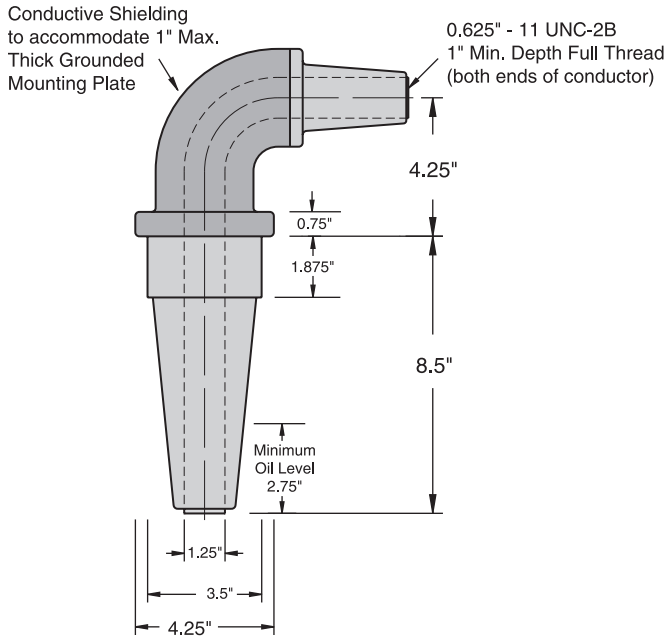

Voltage Class.....	25 kV
Phase-to-Ground Voltage	15.2 kV
BIL	125 kV
A.C. Withstand - 1 Min. Dry	40 kV
D.C. Withstand -15 Min. Dry.....	78 kV
Corona Extinction Level - Minimum.....	19 kV
Continuous Current.....	600 Amps
Momentary - RMS, Asym., 0.2 sec.....	40,000 Amps
RMS, Sym., 4 sec.....	27,000 Amps
Leakage Distance, Inches	8.5
Dry Arcing Distance, Inches	8.5
Mechanical - Strength Rating, Pounds	
Cantilever, Ultimate 2.5 inches past end...>	150
Tensile,Pounds.....>	1,000
Torsion, Inch-Pounds (bolt breaks)	>3,500
Compression,Pounds.....	20,000
Conductor (live end) Thread Size.....	0.625" - 11 x 1"
Net Weight, Pound (kg)	7.47 (3.39)

The Elliott #1611-625L Bushing provides a means for making removable insulated connections of power cables to electrical apparatus (such as switchgear, oil-insulated transformers, etc.). This allows operating personnel to remove the connections, and ground the cable and/or the apparatus for inspection or maintenance. The #1611-625L Bushing is designed for use in oil or SF₆ Gas. The interface accepts 600 Amp, 15 kV or 25 kV IEEE Standard separable insulated connectors (i.e. elbows), and provides a removable, shielded connection to shielded cable.

Typical Specifications - Bushing #1611-625L

Bushings shall be Elliott #1611-625L, 25 kV Class (15.2 kV to ground) Oil Insulated Bushings, 125 kV BIL, per IEEE Standard 386 Fig. 10 (600 A Dead-Break Interface, 8.3 kV and 15.2 kV) for use with either 8.3/14.4 kV or 15.2/26.3 kV separable insulated connectors (Elastimold®, RTE® or other approved equal). The bushings shall be designed for oil insulated operation on the apparatus connection end. The bushings shall be pressure-molded cycloaliphatic epoxy with a 1.25-inch diameter tin plated aluminum conductor on the “oil insulated” side that is drilled and tapped 0.625-inch – 11UNC x 1-inch deep to provide direct connection of the bus and/or live parts. Integral shielding shall be provided to eliminate partial discharge caused by off center mounting and mount-

ing holes that may have sharp edges or burrs. Bushings shall mount in a 3.75-inch diameter opening and clamp in place to allow field replacement with standard tools. The bushing interface shall be free of all voids, holes and heat sinks to assure proper mating with separable insulated connectors. Each bushing shall be tested, mounted in a grounded steel plate not less than 10 inches x 10 inches, and with an insulated protective cap (RTE® #2625041A01 or equal) installed on the interface to accurately simulate operating conditions (gas or liquid dielectric on the interface shall not be acceptable for this test). Each bushing shall meet the requirements for 25 kV devices in accordance with IEEE Standard 386 (latest revision), including 100 percent production testing.

Production Tests

Every bushing is production tested in free air, mounted in an 11-gauge grounded steel plate not less than 10 inches by 10 inches, with an insulated protective cap (RTE® #2625041A01 or equal) installed on the interface to accurately simulate operating conditions. Each bushing must meet or exceed the requirements for 15.2/26.3 kV devices in accordance with the test values of IEEE Standard 386 (latest revision) for partial discharge (corona) and A.C. voltage withstand when tested in this manner.

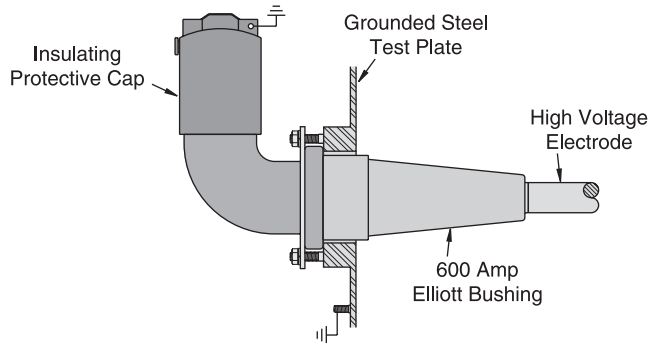

Installation Instructions

The #1611-625L Bushing requires a 3.75" diameter mounting hole and clamps in place with a #1901-8490 clamp ring utilizing six 0.375" - 16 x 1.25" weld studs on a 4.75" bolt circle. All mounting hardware is located on the elbow side of the equipment mounting plate to eliminate the possibility of reduced phase-to-ground clearance.

Every Elliott Bushing is tested at the factory, mounted in a grounded steel plate. A greased insulated protective cap is installed on the interface to accurately simulate operating conditions. To prevent contamination of the silicone grease, it is important to keep the protective cap in place until you are ready to install the elbow (or other device). Should the grease become contaminated, thoroughly clean the interface and reapply silicone grease before installing the elbow.

NOTE: The shipping cap should be left in place to prevent contamination of the interface.

1. The bushing installs from the elbow side for easy installation. The maximum thickness of the equipment plate is 1-inch.
2. A clamp ring is placed on the bushing.
3. Lock washers and nuts are installed on the studs. The nuts should be tightened in a uniform manner rather

than one by one in a random sequence. Do not apply more than 90 inch-pounds torque to each nut. The studs should be left unpainted to provide a connection from the shielding to the grounded mounting plate. If the bushing is mounted on an ungrounded or insulated plate (such as fiberglass) a ground strap should be attached to one of the mounting studs.

IMPORTANT:

This bushing must be installed with the live end immersed in oil a minimum of 2.75" deep to meet electrical ratings.

Do not energize this bushing with only the shipping cap in place. To do so would lead to failure of the bushing and create a hazard to operating personnel. *This product is designed to be used only when it is mated with an appropriate 600 Amp, 15 kV or 25 kV class elbow conforming to the latest revision of IEEE Standard 386. The elbow should be installed in accordance with the instructions supplied by the elbow manufacturer.*

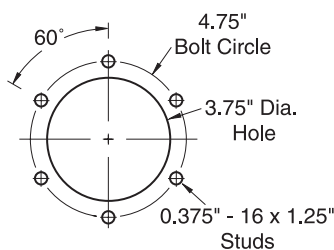

Recommended Mounting

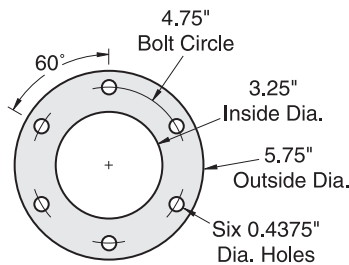

0.1875" Thick #304 SS
Clamp Ring #1901-8490

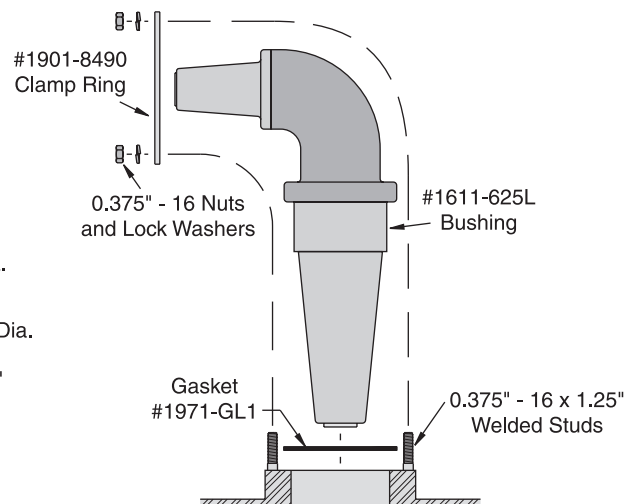



25-kV Apparatus Bushing
"L" Series (clamp-in) for Elbow to Oil Insulated Service
600 Amp

Descriptive
Bulletin
1611-600
Page 4 2008

**If you do not find the design
you need
PLEASE CONTACT
our REPRESENTATIVE or the FACTORY**