

# 35-kV Thru-Bushings

"F" Series (bolt-in) for Air-Insulated to Air-Insulated Service  
200 Amp, 600 Amp and 1250 Amp

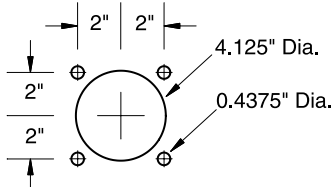

"F" Series Mounting  
Holes 4.125" diameter

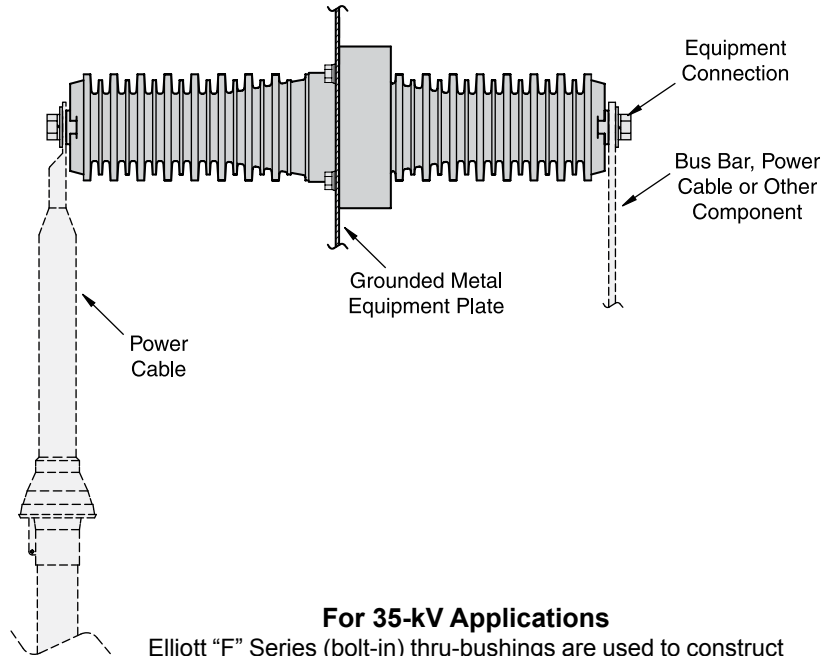

### ELRIM Cycloaliphatic Epoxy Provides:

- Nontracking, self-scouring, nonweathering performance
- Superior dielectric strength, dielectric loss and power factor
- Choice of shapes allows design innovation
- Mechanical and thermal toughness
- Shatter-free arc flashover performance
- Oil resistant

### Elliott Design Provides:

- "Bolt-In" design
- Integral shielding to prevent destructive corona discharge
- Increased leakage distance and square-edge skirts resist contamination - wet or dry
- Generous dry arcing (strike) distance
- Large diameter live end terminal pad with female threads for direct contact of current-carrying parts and improved corona performance
- Thermal cycle withstand from +200° to -200° F for long life
- High Strength - field proven performance since 1975

### For 35-kV Applications

Elliott "F" Series (bolt-in) thru-bushings are used to construct air-insulated equipment that connects to the utility's underground shielded cable system with stress cones or other 35 kV cable terminators. Thru-bushings are also used as roof-bushings, wall-bushings and to construct rear-connected switch and fuse mountings. The same 5-hole mounting provision accommodates all "F" Series bushings (all three 35 kV thru-bushings and the thru-insulator). Gaskets are available when a liquid-tight seal is desirable. Integral shielding prevents "edge-of-hole" corona discharge. The bushing is provided with unique square-edge skirts and increased leakage distance to resist flashover when contaminated and wet. The heavy-duty flange provides excellent cantilever strength so bushings can be used to provide physical support for energized parts. In addition to IEEE Standard 386 design tests, Elliott thru-bushings are design tested for thermal cycle withstand from +200° to -200° F to assure long field life. Every thru-bushing is production tested "in-air" mounted in a grounded steel plate to accurately simulate operating conditions.

### Ratings and Dimensions of Thru-Bushings & Thru-Insulator

Catalog Number	Voltage Class kV	Continuous Current Amps	Withstand Test Voltage Kilovolts			Minimum Leakage Inches	Minimum Strike Inches
			Impulse 1.2 x 50	One Min. Dry	10 Sec. Dew		
1352-235TB	35	200	150	50	50	24	10
1352-635TB	35	600	150	50	50	24	10
1352-1235TB	35	1250	150	50	50	24	10
1352-035T1 Thru-Insulator	35	N/A	150	50	50	24	10

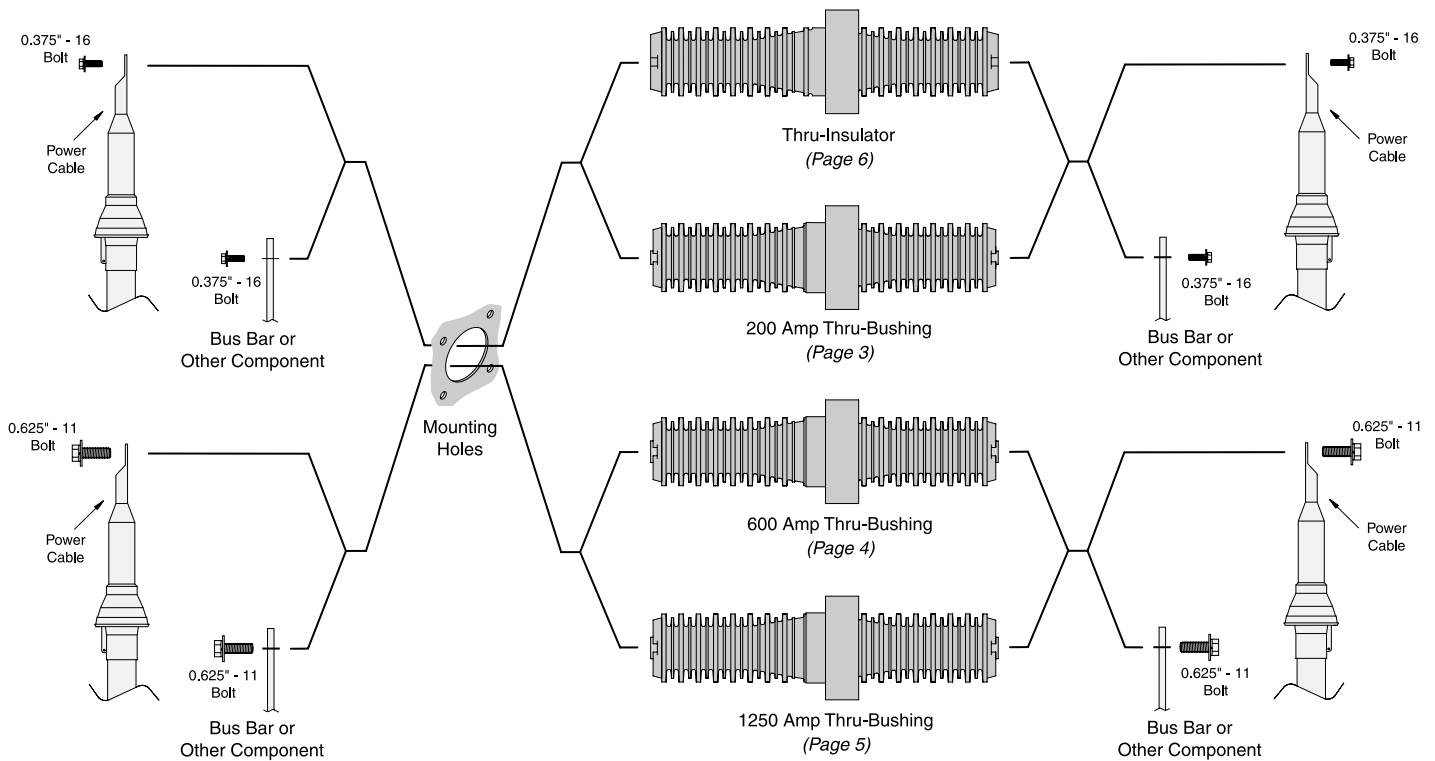

**Common Mounting** - All “F” series bushings have the same mounting bolt pattern. The installer can punch one mounting hole pattern and install any “F” series bushing or insulator. For example, equipment can be designed for 600 amp bushings, but actually be assembled with 600 and 200 amp bushings. A “bushing-style” insulator can be used to support one end of a bus bar, and be replaced in the field with a 200 or 600 amp bushing.

**Index Slots** - Elliott “F” series bushings and insulators feature four keying slots on the live end. Fuse clips and hinge kits are available that bolt directly to the bushing conductor (or the thru-insulator insert) and key in the slots to prevent rotation.

**Conductor Connection** - Female threads in the live end of the conductor allow the attachment of live parts of almost any thickness. The bolted connection of current-carrying parts does not depend on current transfer through the fastener’s thread-to-thread contact. Additional advantages of the bolted connection are higher clamping pressure and elimination of exposed sharp threads that could initiate corona.

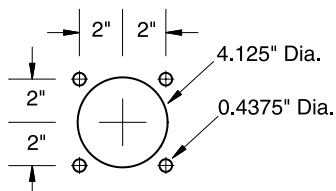

**“F” Series Mounting Holes**  
4.125” Diameter



# 35-kV Thru-Bushings

“F” Series (bolt-in) for Air-Insulated to Air-Insulated Service  
200 Amp, 600 Amp and 1250 Amp

Descriptive  
Bulletin  
**1352**  
Page 3    2008

## 200 Amp Thru-Bushing #1352-235TB

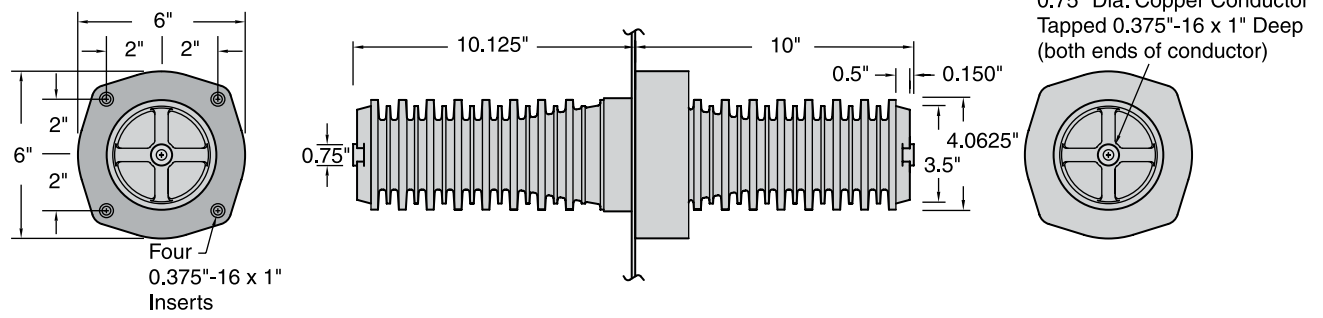

Voltage Class.....	35 kV
Phase-to-Ground Voltage.....	21.1 kV
BIL.....	150 kV
A.C. Withstand - 1 Min. Dry.....	50 kV
10 Sec. Dew.....	50 kV
D.C. Withstand - 15 Min. Dry.....	103 kV
Corona Extinction Level - Minimum.....	>26 kV
Continuous Current.....	200 Amps
Momentary - RMS, Sym., 0.17 sec.....	10,000 Amps
RMS, Sym., 3 sec.....	3,500 Amps

Leakage Distance, Inches.....	>24
Dry Arcing Distance, Inches.....	10
Mechanical - Strength Rating, Pounds	
Cantilever, Ultimate 2.5 inches past end.....	>450
Tensile, Pounds.....	>2,500
Torsion, Inches-Pounds.....	>700
Compression, Pounds.....	20,000
Insert Thread Size.....	0.375" - 16 x 1"
Conductor (live end) Thread Size.....	0.375" - 16 x 1"
Net Weight, Pounds (kg).....	16.47 (7.48)

### Typical Specifications - 200 Amp 35-kV Thru-Bushing

Bushings shall be 200 ampere Elliott #1352-235TB, 35 kV Class (21.1 kV to ground) Air-Insulated Live Terminal Thru-Bushings, 150 kV BIL, for use with 21.1/36.6 kV systems. The bushings shall be pressure-molded cycloaliphatic epoxy with a 0.75-inch diameter copper conductor that is drilled and tapped 0.375-inch – 16UNC x 1-inch deep on both ends to provide for connection of the bus and/or live parts. Integral shielding shall be provided to eliminate partial discharge caused by off-center mounting and mounting holes that may have sharp edges or burrs. Bushings shall mount in a 4.125-inch diameter opening and bolt in place to allow

field replacement with standard tools. To assure adequate strength for apparatus support, the bushing shall withstand a minimum cantilever loading of 250 pounds for five minutes without damage. The bushing mounting bolts shall be self-locking stainless steel serrated flange hex-head bolts that “cut” through the enclosure protective finish to ground the integral shielding of each bushing. Each bushing shall be tested in free air, mounted in a grounded steel plate not less than 10 inches x 10 inches and shall meet the requirements for 35 kV devices in accordance with IEEE Standard 386 (latest revision), including 100 percent production testing.



# 35-kV Thru-Bushings

“F” Series (bolt-in) for Air-Insulated to Air-Insulated Service  
200 Amp, 600 Amp and 1250 Amp

Descriptive  
Bulletin  
**1352**  
Page 4    2008

## 600 Amp Thru-Bushing #1352-635TB

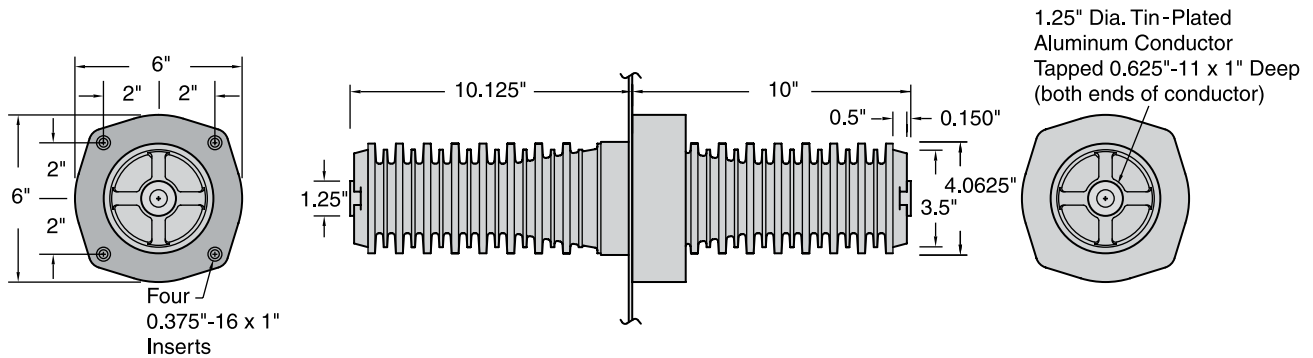

Voltage Class.....	35 kV
Phase-to-Ground Voltage.....	21.1 kV
BIL.....	150 kV
A.C. Withstand - 1 Min. Dry.....	50 kV
10 Sec. Dew.....	50 kV
D.C. Withstand - 15 Min. Dry.....	103 kV
Corona Extinction Level - Minimum.....	>26 kV
Continuous Current.....	600 Amps
Momentary - RMS, Sym., 0.17 sec.....	25,000 Amps
RMS, Sym., 3 sec.....	10,000 Amps

Leakage Distance, Inches.....	>24
Dry Arcing Distance, Inches.....	10
Mechanical - Strength Rating, Pounds	
Cantilever, Ultimate 2.5 inches past end.....	>900
Tensile, Pounds.....	>4,000
Torsion, Inches-Pounds.....	>2,500
Compression, Pounds.....	20,000
Insert Thread Size.....	0.375" - 16 x 1"
Conductor (live end) Thread Size.....	0.625" - 11 x 1"
Net Weight, Pounds (kg).....	14.04 (6.37)

### Typical Specifications - 600 Amp 35-kV Thru-Bushing

Bushings shall be 600 ampere Elliott #1352-635TB, 35 kV Class (21.1 kV to ground) Air-Insulated Live Terminal Thru-Bushings, 150 kV BIL, for use with 21.1/36.6 kV systems. The bushings shall be pressure-molded cycloaliphatic epoxy with a 1.25-inch diameter tin-plated aluminum conductor that is drilled and tapped 0.625-inch – 11UNC x 1-inch deep on both ends to provide for connection of the bus and/or live parts. Integral shielding shall be provided to eliminate partial discharge caused by off-center mounting and mounting holes that may have sharp edges or burrs. Bushings shall mount in a 4.125-inch diameter opening and bolt in place to allow field replacement with standard tools. To assure

adequate strength for apparatus support, the bushing shall withstand a minimum cantilever loading of 500 pounds for five minutes without damage. The bushing mounting bolts shall be self-locking stainless steel serrated flange hex-head bolts that “cut” through the enclosure protective finish to ground the integral shielding of each bushing. Each bushing shall be tested in free air, mounted in a grounded steel plate not less than 10 inches x 10 inches and shall meet the requirements for 35 kV devices in accordance with IEEE Standard 386 (latest revision), including 100 percent production testing.



# 35-kV Thru-Bushings

“F” Series (bolt-in) for Air-Insulated to Air-Insulated Service  
200 Amp, 600 Amp and 1250 Amp

Descriptive  
Bulletin  
**1352**  
Page 5    2008

## 1250 Amp Thru-Bushing #1352-1235TB

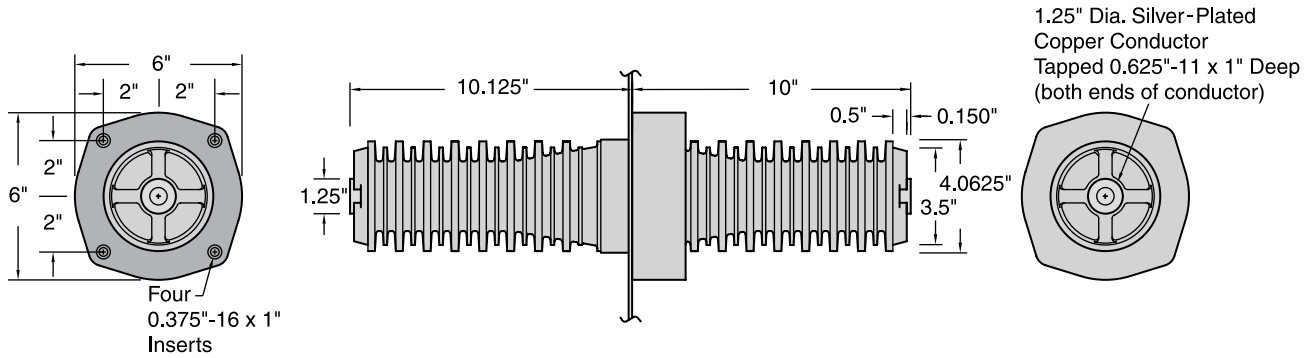

Voltage Class.....	35 kV
Phase-to-Ground Voltage.....	21.1 kV
BIL.....	150 kV
A.C. Withstand - 1 Min. Dry.....	50 kV
10 Sec. Dew.....	50 kV
D.C. Withstand - 15 Min. Dry.....	103 kV
Corona Extinction Level - Minimum.....	>26 kV
Continuous Current.....	1,250 Amps
Momentary - RMS, Sym., 0.17 sec.....	25,000 Amps
RMS, Sym., 3 sec.....	10,000 Amps

Leakage Distance, Inches.....	>24
Dry Arcing Distance, Inches.....	10
Mechanical - Strength Rating, Pounds	
Cantilever, Ultimate 2.5 inches past end.....	>900
Tensile, Pounds.....	>4,000
Torsion, Inches-Pounds.....	>2,500
Compression, Pounds.....	20,000
Insert Thread Size.....	0.375" - 16 x 1"
Conductor (live end) Thread Size.....	0.625" - 11 x 1"
Net Weight, Pounds (kg).....	19.35 (8.78)

### Typical Specifications - 1250 Amp 35-kV Thru-Bushing

Bushings shall be 1250 ampere Elliott #1352-1235TB, 35 kV Class (21.1 kV to ground) Air-Insulated Live Terminal Thru-Bushings, 150 kV BIL, for use with 21.1/36.6 kV systems. The bushings shall be pressure-molded cycloaliphatic epoxy with a 1.25-inch diameter silver-plated copper conductor that is drilled and tapped 0.625-inch – 11UNC x 1-inch deep on both ends to provide for connection of the bus and/or live parts. Integral shielding shall be provided to eliminate partial discharge caused by off-center mounting and mounting holes that may have sharp edges or burrs. Bushings shall mount in a 4.125-inch diameter opening and bolt in place to allow field replacement with standard

tools. To assure adequate strength for apparatus support, the bushing shall withstand a minimum cantilever loading of 500 pounds for five minutes without damage. The bushing mounting bolts shall be self-locking stainless steel serrated flange hex-head bolts that “cut” through the enclosure protective finish to ground the integral shielding of each bushing. Each bushing shall be tested in free air, mounted in a grounded steel plate not less than 10 inches x 10 inches and shall meet the requirements for 35 kV devices in accordance with the test values of IEEE Standard 386 (latest revision), including 100 percent production testing.



# 35-kV Thru-Bushings

“F” Series (bolt-in) for Air-Insulated to Air-Insulated Service  
200 Amp, 600 Amp and 1250 Amp

Descriptive  
Bulletin  
**1352**  
Page 6    2008

## Thru-Insulator #1352-035TI

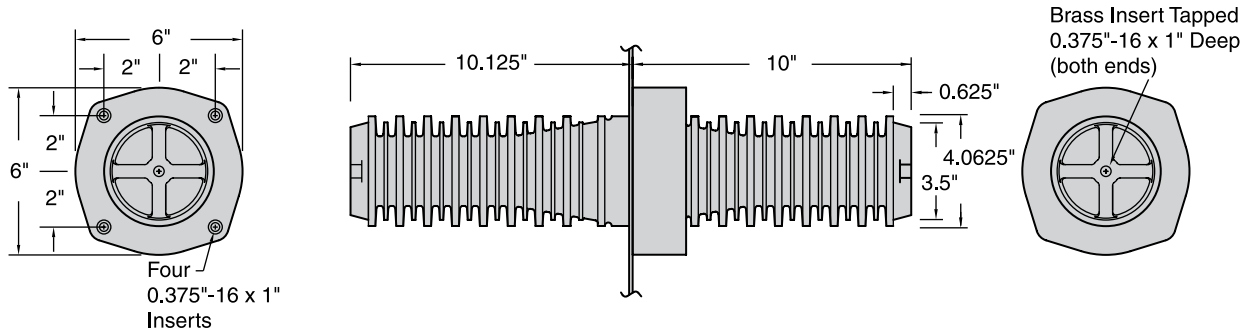

Voltage Class.....	35 kV
Phase-to-Ground Voltage.....	21.1 kV
BIL .....	150 kV
A.C. Withstand - 1 Min. Dry.....	50 kV
10 Sec. Dew.....	50 kV
D.C. Withstand - 15 Min. Dry.....	103 kV
Corona Extinction Level - Minimum.....	>26 kV
Continuous Current .....	N/A
Momentary - RMS, Sym., 0.17 sec.....	N/A
RMS, Sym., 3 sec.....	N/A

Leakage Distance, Inches.....	>24
Dry Arcing Distance, Inches.....	10
Mechanical - Strength Rating, Pounds	
Cantilever, Ultimate 2.5 inches past end.....	>1,000
Tensile, Pounds.....	>3,000
Torsion, Inches-Pounds .....	>1,500
Compression, Pounds.....	20,000
Insert Thread Size.....	0.375" - 16 x 1"
Conductor (live end) Thread Size .....	0.375" - 16 x 1"
Net Weight, Pounds (kg).....	12.96 (5.88)

### Typical Specifications - 35-kV “Bushing-Style” Thru-Insulators

Insulators shall be Elliott #1352-035TI, 35 kV Class (21.1 kV to ground) Air-Insulated “Bushing-Style” Thru-Insulators, 150 kV BIL, for use with 21.1/36.6 kV systems. The insulators shall be nontracking, self-scouring, nonweathering pressure-molded cycloaliphatic epoxy with cast-in-place brass inserts. The brass inserts shall be drilled and tapped 0.375-inch – 16UNC x 1-inch deep to provide for connection of the bus and/or live parts. The skirts shall be square-edge design to provide 24 inches or more leakage distance for superior contamination resistance. Surface damage to insulators shall expose material of the same composition

and characteristics so insulators with minor surface damage will not require replacement. The insulators shall provide adequate thermal cycle withstand to assure trouble-free field service in the most severe climatic conditions established by in-house testing and field operating experience. Insulators shall mount in a 4.125-inch diameter opening and bolt in place to allow field replacement with standard tools. To assure adequate strength for apparatus support, the insulator shall withstand a minimum cantilever loading of 600 pounds for five minutes without damage. The insulator mounting bolts shall be self-locking stainless steel serrated flange hex-head bolts.

### Production Test

Every bushing is production tested in free air, mounted in an 11-gauge grounded steel plate not less than 10 inches x 10 inches, to accurately simulate operating conditions. Each bushing must meet or exceed the requirements for 21.1/36.6 kV devices in accordance with the test values of IEEE Standard 386 (latest revision) for partial discharge (corona) and A.C. voltage withstand when tested in this manner.

### Test Configuration

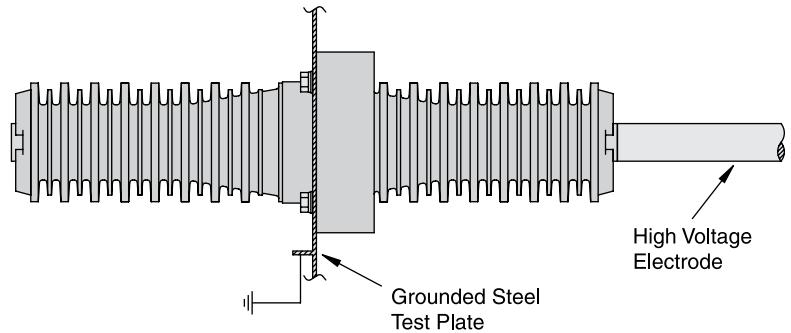

### Installation Instructions

Elliott "F" Series Apparatus Bushings require a 4.125" diameter mounting hole with four 0.4375" diameter bolt holes. The thru-bushing bolts in place utilizing four 0.375" - 16 x 1" serrated flange hex-head bolts (or bolts with external tooth lock washers). Gaskets are available when a liquid-tight seal is desirable.

35 kV Thru-Bushings mount on either side of the mounting hole. When installed in a 0.125" plate, both sides of the bushing extend 10 inches.

1. The thru-bushing installs from either side for easy installation.
2. Serrated flange bolts (or bolts and external tooth lock washers) are installed. The bolts should be tightened in a uniform manner (rather than one-by-one in a random sequence). Do not apply more than 90 inch-pounds torque to each bolt. The serrated flange bolts (or external tooth lock washers) must "cut" into the mounting plate to provide a connection from the shielding to the grounded mounting plate. If the bushing is mounted on an ungrounded or insulated plate (such as fiberglass), a ground strap should be attached to one of the mounting bolts.

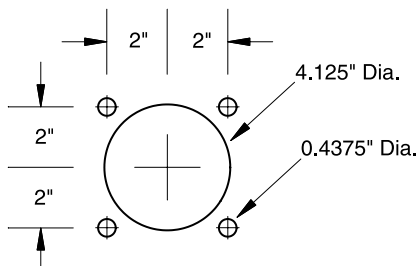

**4.125" Dia. Mounting Hole  
for Elliott "F" Series Bushings**

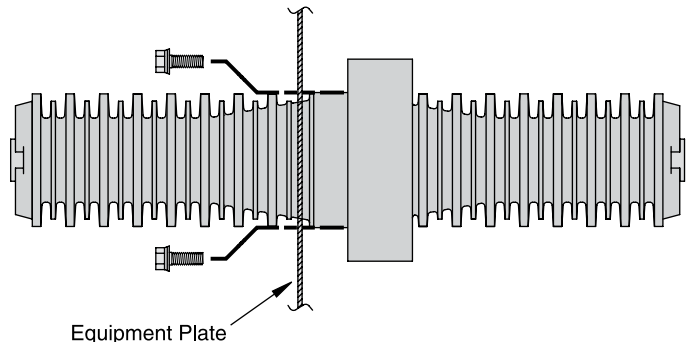



**35-kV Thru-Bushings**  
"F" Series (bolt-in) for Air-Insulated to Air-Insulated Service  
200 Amp, 600 Amp and 1250 Amp

Descriptive  
Bulletin  
**1352**  
Page 8 2008

**If you do not find the design  
you need  
PLEASE CONTACT  
our REPRESENTATIVE or the FACTORY**