

ELRIM Cycloaliphatic Epoxy Provides:

- Nontracking, self-scouring, nonweathering performance
- Superior dielectric strength, dielectric loss and power factor
- Choice of shapes allows design innovation
- Mechanical and thermal toughness
- Shatter free arc flashover performance
- Oil resistant

Elliott Design Provides:

- Precision molded interfaces per IEEE Standard 386
- Uni-Mount "Bolt-In" design
- Integral shielding to prevent destructive corona discharge
- Thermal cycle withstand from +200° to -200° F for long life
- High Strength - field proven performance since 1975

For 35-kV Connectors (Elbows)

Elliott "B" Series (bolt-in) apparatus bushings are used to construct air-insulated equipment that connects to the utility's underground shielded cable system with IEEE Standard separable insulated connectors (i.e. elbows). The same 5-hole mounting provision accommodates all "B" Series bushings (the Uni-Mount hole pattern will accommodate Elliott "B" bushings and S&C bushings). Integral shielding prevents "edge-of-hole" corona discharge. The heavy-duty flange provides exceptionally high cantilever strength. In addition to IEEE Standard 386 design tests, Elliott bushings are design tested for thermal cycle withstand from +200° to -200° F to assure long field life. Every bushing is production tested "in-air" mounted in a grounded steel plate with an insulated bushing extension (or bushing extension and protective cap) installed on the interface to accurately simulate operating conditions.

Ratings and Dimensions of Double Bushing Wells, Double Bushings and Parking Bushings

Catalog Number	Voltage Class kV	Continuous Current Amps	Withstand Test Voltage Kilovolts			Minimum Leakage Inches	Minimum Strike Inches
			Impulse 1.2 x 50	One Min. Dry	10 Sec. Dew		
1335-235B-DW	35	200	150	50	N/A	N/A	N/A
1335-635B-DB	35	600	150	50	N/A	N/A	N/A
1335-1235B-DB	35	1250	150	50	N/A	N/A	N/A
1335-635B-PB Parking Bushing	35	N/A	150	50	N/A	N/A	N/A
1335-635B-DPB Double Parking Bushing	35	N/A	150	50	N/A	N/A	N/A

35-kV Apparatus Bushing

"B" Series (bolt-in) for Elbow-to-Elbow Service
200 Amp, 600 Amp, and 1250 Amp

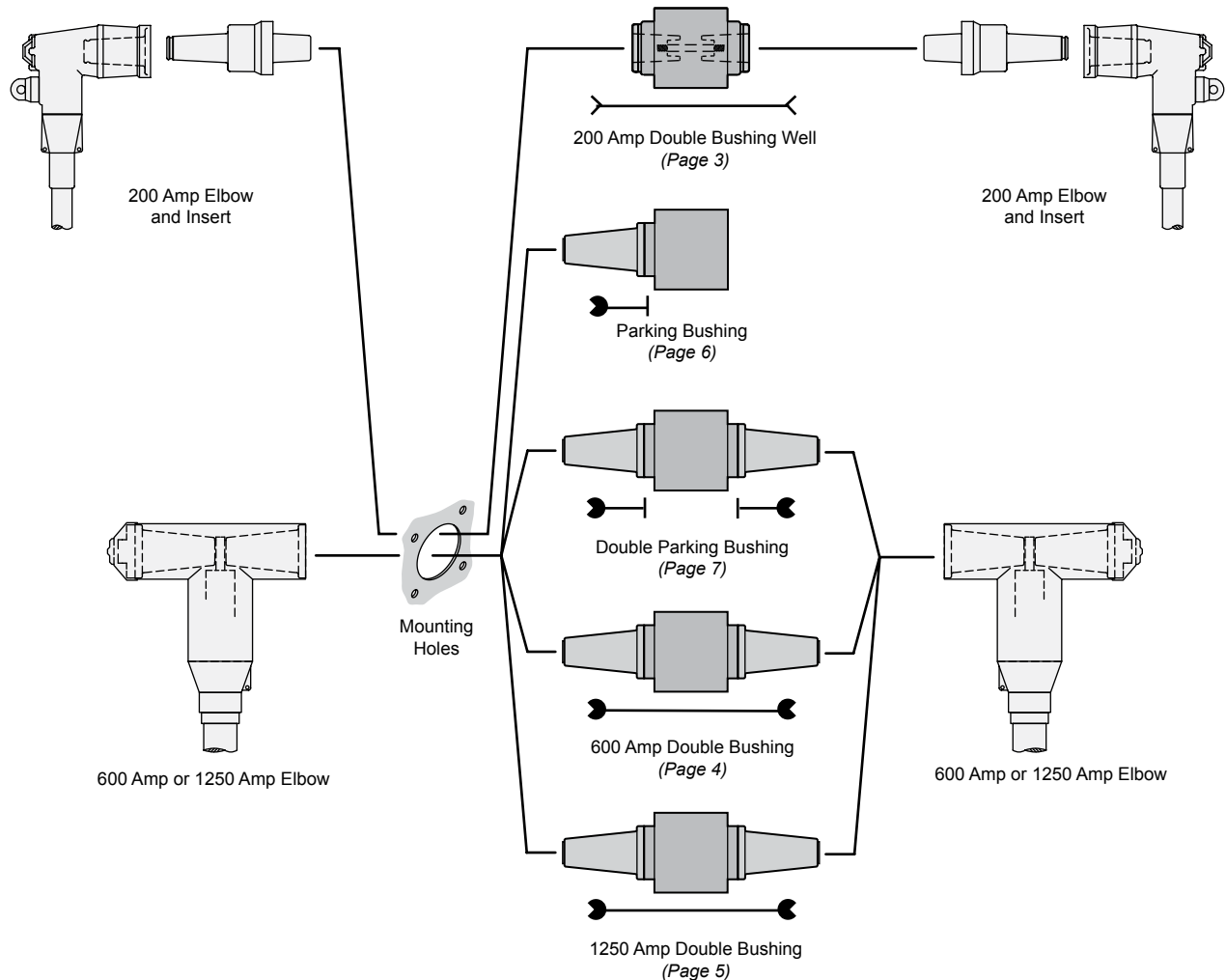

Elliott Double Bushing Wells are designed to accept IEEE Standard Fig. 3 Loadbreak Insert and Elbows. **Elliott Double Bushings and Parking Bushings** are designed to accept 600 amp or 1250 amp Elbows. Double Bushing Wells and Bushings include a conductor between the two interfaces to provide a means of electrically connecting one elbow to another. Parking Bushings provide an insulated interface as a means to "park" an elbow with an energized cable.

These products can be used to:

- Construct pad-mounted switchgear using Double Bushing Wells and Double Bushings.
- Install a parking bushing next to an apparatus bushing for use with the Elastimold Link-Op™ connection system.
- Mount Double Bushing on wall brackets in vaults or industrial locations as a way to connect several 600 amp elbows.
- Install a parking bushing to provide a permanent parking device for 600 amp elbow.

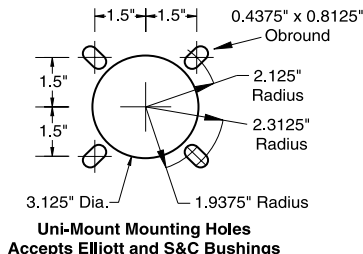
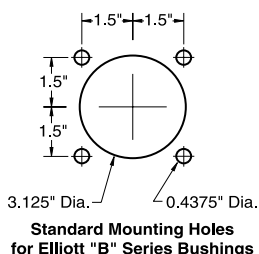

Common Mounting — All "B" series bushings have the same mounting-bolt pattern. The installer can punch one mounting-hole pattern (either Standard or Uni-Mount) and install any "B" series bushing, insulator or parking bushing.

Other Designs Available — In addition to the 200 amp, 600 amp and 1250 amp 35 kV designs, we also offer designs with 200 amp, 600 amp and 1250 amp interfaces for 15 kV and 25 kV devices. Please contact our representative or the factory.

200 Amp Double Bushing Well # 1335-235B-DW

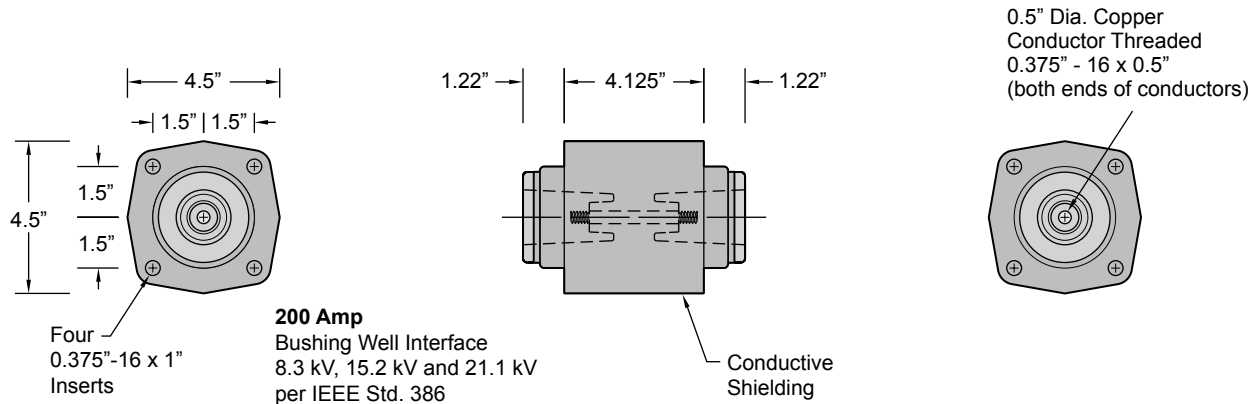

Voltage Class.....	35 kV
Phase-to-Ground Voltage.....	21.1 kV
BIL.....	150 kV
A.C. Withstand - 1 Min. Dry.....	50 kV
10 Sec. Dew.....	N/A
D.C. Withstand - 15 Min. Dry.....	103 kV
Corona Extinction Level - Minimum.....	26 kV
Continuous Current.....	200 Amps
Momentary - RMS, Sym., 0.17 sec.....	10,000 Amps
RMS, Sym., 3 sec.....	3,500 Amps

Leakage Distance, Inches.....	N/A
Dry Arcing Distance, Inches.....	N/A
Mechanical - Strength Rating, Pounds	
Cantilever, Ultimate 2.5 inches past end.....	>1,000
Tensile, Pounds.....	>5,000
Torsion, Inches-Pounds (bolt breaks).....	>700
Compression, Pounds.....	20,000
Insert Thread Size.....	0.375" - 16 x 1"
Conductor Thread Size.....	0.375" - 16 x 0.5"
Net Weight, Pounds (kg).....	5.07 (2.30)

Typical Specifications — 200 Amp 35-kV Double Bushing Wells

Bushing Wells shall be 200 ampere Elliott #1335-235B-DW, 35 kV class (21.1 kV to ground) Bushing Wells, 150 kV BIL, per IEEE Standard 386 Fig. 3 (200 A Bushing Well Interface, 21.1 kV) for use with 21.1/36.6 kV separable insulated connectors (Elastimold® or other approved equal). The bushing wells shall be pressure-molded cycloaliphatic epoxy with a 0.5-inch diameter copper conductor that is threaded 0.375-inch – 16UNC on both ends. Integral shielding shall be provided to eliminate partial discharge caused by off-center mounting and mounting holes that may have sharp edges or burrs. Double Bushing Wells shall mount in a 3.125-inch diameter opening and bolt in place to allow field replacement with standard tools. The bushing mounting bolts shall be self locking stainless steel serrated flange hex-head bolts that "cut" through the enclosure's protective finish to

ground the integral shielding of each bushing. To assure adequate strength for apparatus support, the bushing shall withstand a minimum cantilever loading of 600 pounds for five minutes without damage. The bushing well interface shall be free of all voids, holes and heat sinks to assure proper mating with separable insulated connectors. Each Double Bushing Well shall be tested in free air, mounted in a grounded steel plate not less than 10 inches x 10 inches, and with a bushing well plug (RTE® #IBWP225 or equal) installed in the well interface to accurately simulate operating conditions (gas or liquid dielectric on the interface shall not be acceptable for this test). Each bushing well shall meet the requirements for 35 kV devices in accordance with IEEE Standard 386 (latest revision), including 100 percent production testing.



35-kV Apparatus Bushing

“B” Series (bolt-in) for Elbow-to-Elbow Service
200 Amp, 600 Amp, and 1250 Amp

Descriptive
Bulletin
1035-250
Page 4 2011

600 Amp Double Bushing #1335-635B-DB

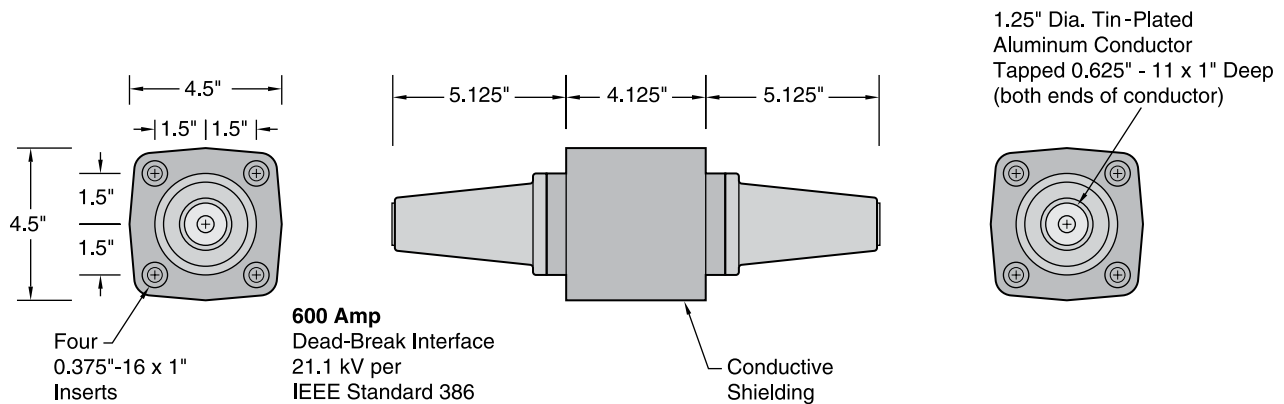

Voltage Class.....	35 kV
Phase-to-Ground Voltage.....	21.1 kV
BIL.....	150 kV
A.C. Withstand - 1 Min. Dry.....	50 kV
10 Sec. Dew.....	N/A
D.C. Withstand - 15 Min. Dry.....	103 kV
Corona Extinction Level - Minimum.....	26 kV
Continuous Current.....	600 Amps
Momentary - RMS, Sym., 0.17 sec.....	25,000 Am
RMS, Sym., 3 sec.....	10,000 Amps

Leakage Distance, Inches.....	N/A
Dry Arcing Distance, Inches.....	N/A
Mechanical - Strength Rating, Pounds	
Cantilever, Ultimate 2.5 inches past end.....	>1,000
Tensile, Pounds.....	>5,000
Torsion, Inches-Pounds (bolt breaks).....	>3,000
Compression, Pounds.....	20,000
Insert Thread Size.....	0.375" - 16 x 1"
Conductor Thread Size.....	0.625" - 11 x 1"
Net Weight, Pounds (kg).....	8.08 (3.67)

Typical Specifications - 600 Amp 35-kV Bushings

Double Bushings shall be 600 ampere Elliott #1335-635B-DB, 35 kV class (21.1 kV to ground) Bushings, 150 kV BIL, per IEEE Standard 386 Fig. 11 (600 A Dead-Break Interface, 21.1 kV) for use with 21.1/36.6 kV separable insulated connectors (Elastimold®, Cooper Power Systems [RTE®] or other approved equal). The bushings shall be pressure-molded cycloaliphatic epoxy with a 1.25-inch diameter tin-plated aluminum conductor that is drilled and tapped 0.625-inch – 11UNC x 1-inch deep on both ends. Integral shielding shall be provided to eliminate partial discharge caused by off-center mounting and mounting holes that may have sharp edges or burrs. Double Bushings shall mount in a 3.125-inch diameter opening and bolt in place to allow field replacement with standard tools. The bushing mounting bolts shall be self-locking stainless steel serrated flange hex-head bolts that “cut” through the

enclosure protective finish to ground the integral shielding of each bushing. To assure adequate strength for apparatus support, the bushing shall withstand a minimum cantilever loading of 600 pounds for five minutes without damage. The bushing interface shall be free of all voids, holes and heat sinks to assure proper mating with separable insulated connectors. Each bushing shall be tested in free air, mounted in a grounded steel plate not less than 10 inches x 10 inches, and with an insulated protective cap (RTE® #DPC635 or equal) installed on one interface and an insulated bushing extension (RTE® #DBE635 or equal) installed on the other interface to accurately simulate operating conditions (gas or liquid dielectric on the interface shall not be acceptable for this test). Each bushing shall meet the requirements for 35 kV devices in accordance with IEEE Standard 386 (latest revision), including 100 percent production testing.



35-kV Apparatus Bushings

“B” Series (bolt-in) for Elbow-to-Elbow Service
200 Amp, 600 Amp and 1250 Amp

Descriptive
Bulletin
1035-250
Page 5 2011

1250 Amp Double Bushing #1335-1235B-DB

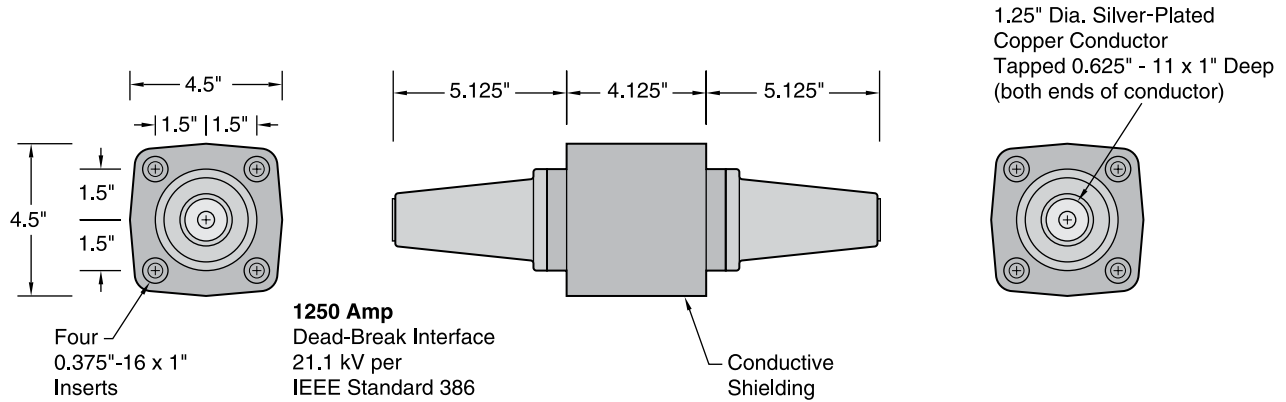

1250 Amp Dead-Break Interface	21.1 kV per IEEE Standard 386
Voltage Class.....	35 kV
Phase-to-Ground Voltage.....	21.1 kV
BIL.....	150 kV
A.C. Withstand - 1 Min. Dry.....	50 kV
10 Sec. Dew.....	N/A
D.C. Withstand - 15 Min. Dry.....	103 kV
Corona Extinction Level - Minimum.....	26 kV
Continuous Current.....	1250 Amps
Momentary - RMS, Sym., 0.17 sec.....	25,000 Amps
RMS, Sym., 3 sec.....	10,000 Amps

Leakage Distance, Inches.....	N/A
Dry Arcing Distance, Inches.....	N/A
Mechanical - Strength Rating, Pounds	
Cantilever, Ultimate 2.5 inches past end.....	>1,000
Tensile, Pounds.....	>5,000
Torsion, Inches-Pounds (bolt breaks).....	>3,000
Compression, Pounds.....	20,000
Insert Thread Size.....	0.375" - 16 x 1"
Conductor Thread Size.....	0.625" - 11 x 1"
Net Weight, Pounds (kg).....	11.48 (5.21)

Typical Specifications—1250 Amp 35-kV Double Bushings

Double Bushings shall be 1250 ampere Elliott #1335-1235B-DB, 35 kV class (21.1 kV to ground) Bushings, 150 kV BIL, per IEEE Standard 386 Fig. 11 (600 A Dead-Break Interface, 21.1 kV) for use with 21.1/36.6 kV separable insulated connectors (Elastimold®, Cooper Power Systems [RTE®] or other approved equal). The bushings shall be pressure-molded cycloaliphatic epoxy with a 1.25-inch diameter silver plated copper conductor that is drilled and tapped 0.625-inch – 11UNC x 1-inch deep on both ends. Integral shielding shall be provided to eliminate partial discharge caused by off-center mounting and mounting holes that may have sharp edges or burrs. Double Bushings shall mount in a 3.125-inch diameter opening and bolt in place to allow field replacement with standard tools. The bushing mounting bolts shall be self-locking stainless steel serrated flange hex-head bolts that “cut” through the

enclosure protective finish to ground the integral shielding of each bushing. To assure adequate strength for apparatus support, the bushing shall withstand a minimum cantilever loading of 600 pounds for five minutes without damage. The bushing interface shall be free of all voids, holes and heat sinks to assure proper mating with separable insulated connectors. Each bushing shall be tested in free air, mounted in a grounded steel plate not less than 10 inches x 10 inches, and with an insulated protective cap (RTE® #DPC635 or equal) installed on one interface and an insulated bushing extension (RTE® #DBE635 or equal) installed on the other interface to accurately simulate operating conditions (*gas or liquid dielectric on the interface shall not be acceptable for this test*). Each bushing shall meet the requirements for 35 kV devices in accordance with IEEE Standard 386 (latest revision), including 100 percent production testing.



35-kV Apparatus Bushing

“B” Series (bolt-in) for Elbow-to-Elbow Service
200 Amp, 600 Amp, and 1250 Amp

Descriptive
Bulletin
1035-250
Page 6 2011

Parking Bushing #1335-635B-PB

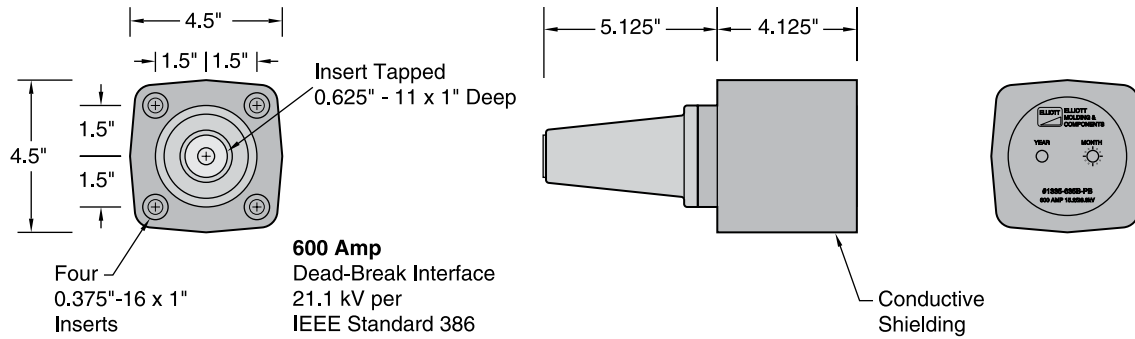

Voltage Class.....	35 kV
Phase-to-Ground Voltage.....	21.1 kV
BIL.....	150 kV
A.C. Withstand - 1 Min. Dry.....	50 kV
10 Sec. Dew.....	N/A
D.C. Withstand - 15 Min. Dry.....	103 kV
Corona Extinction Level - Minimum.....	26 kV
Continuous Current.....	N/A
Momentary - RMS, Sym., 0.17 sec.....	N/A
RMS, Sym., 3 sec.....	N/A

Leakage Distance, Inches.....	N/A
Dry Arcing Distance, Inches.....	N/A
Mechanical - Strength Rating, Pounds	
Cantilever, Ultimate 2.5 inches past end.....	>1,000
Tensile, Pounds.....	>5,000
Torsion, Inches-Pounds (bolt breaks).....	>3,000
Compression, Pounds.....	20,000
Insert Thread Size.....	0.375" - 16 x 1"
Conductor Insert Thread Size.....	0.625" - 11 x 1"
Net Weight, Pounds (kg).....	6.57 (2.98)

Typical Specifications — 600 Amp 35-kV Parking Bushings

Parking Bushings shall be Elliott #1335-635B-PB, 35 kV class (21.1 kV to ground) Bushings, 150 kV BIL, per IEEE Standard 386 Fig. 11 (600 A Dead-Break Interface, 21.1 kV) for use with 21.1/36.6 kV separable insulated connectors (Elastimold®, Cooper Power Systems [RTE®] or other approved equal). The bushings shall be pressure-molded cycloaliphatic epoxy with a 1.25-inch diameter aluminum insert that is drilled and tapped 0.625-inch – 11UNC x 1-inch deep. Integral shielding shall be provided to eliminate partial discharge caused by off-center mounting and mounting holes that may have sharp edges or burrs. Parking Bushings shall mount in a 3.125-inch diameter opening and bolt in place to allow field replacement with standard tools. The bushing mounting bolts shall be self-locking stainless steel serrated flange hex-head

bolts that “cut” through the enclosure protective finish to ground the integral shielding of each bushing. To assure adequate strength for apparatus support, the bushing shall withstand a minimum cantilever loading of 600 pounds for five minutes without damage. The bushing interface shall be free of all voids, holes and heat sinks to assure proper mating with separable insulated connectors. Each bushing shall be tested in free air, mounted in a grounded steel plate not less than 10 inches x 10 inches, and with an insulated bushing extension (RTE® #DBE635 or equal) installed on the interface to accurately simulate operating conditions (*gas or liquid dielectric on the interface shall not be acceptable for this test*). Each bushing shall meet the requirements for 35 kV devices in accordance with IEEE Standard 386 (latest revision), including 100 percent production testing.



35-kV Apparatus Bushings

“B” Series (bolt-in) for Elbow-to-Elbow Service
200 Amp, 600 Amp and 1250 Amp

Descriptive
Bulletin
1035-250
Page 7 2011

Double Parking Bushing #1335-635B-DPB

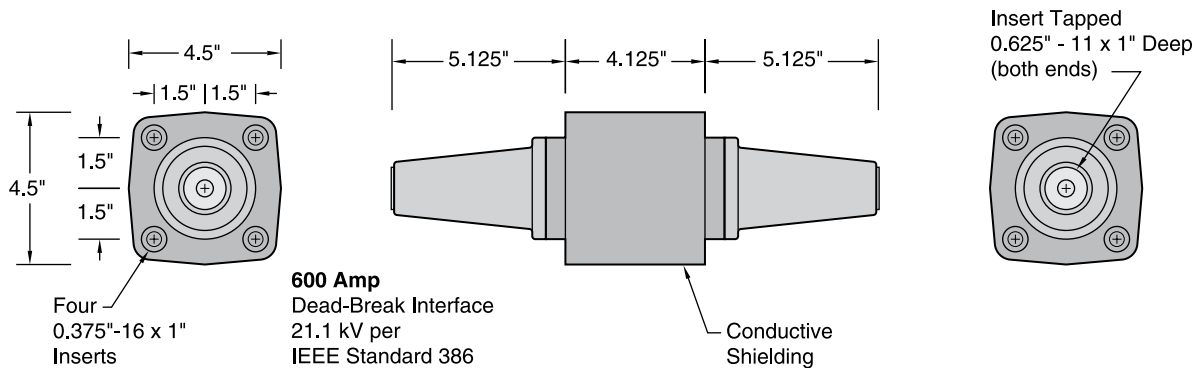

Voltage Class.....	35 kV
Phase-to-Ground Voltage.....	21.1 kV
BIL.....	150 kV
A.C. Withstand - 1 Min. Dry.....	50 kV
10 Sec. Dew.....	N/A
D.C. Withstand - 15 Min. Dry.....	103 kV
Corona Extinction Level - Minimum.....	26 kV
Continuous Current.....	N/A
Momentary - RMS, Sym., 0.17 sec.....	N/A
RMS, Sym., 3 sec.....	N/A

Leakage Distance, Inches.....	N/A
Dry Arcing Distance, Inches.....	N/A
Mechanical - Strength Rating, Pounds	
Cantilever, Ultimate 2.5 inches past end.....	>1,000
Tensile, Pounds.....	>5,000
Torsion, Inches-Pounds (bolt breaks).....	>3,000
Compression, Pounds.....	20,000
Insert Thread Size.....	0.375" - 16 x 1"
Conductor Insert Thread Size.....	0.625" - 11 x 1"
Net Weight, Pounds (kg).....	8.00 (3.64)

Typical Specifications — 600 Amp 35-kV Double Parking Bushings

Double Parking Bushings shall be Elliott #1335-635B-DPB, 35 kV class (21.1 kV to ground) Bushings, 150 kV BIL, per IEEE Standard 386 Fig. 11 (600 A Dead-Break Interface, 21.1 kV) for use with 21.1/36.6 kV separable insulated connectors (Elastimold®, Cooper Power Systems [RTE®] or other approved equal). The bushings shall be pressure-molded cycloaliphatic epoxy with two 1.25-inch diameter aluminum inserts that are drilled and tapped 0.625-inch – 11UNC x 1-inch deep. Integral shielding shall be provided to eliminate partial discharge caused by off-center mounting and mounting holes that may have sharp edges or burrs. Double Parking Bushings shall mount in a 3.125-inch diameter opening and bolt in place to allow field replacement with standard tools. The bushing mounting bolts shall be self-locking stainless steel serrated flange

hex-head bolts that “cut” through the enclosure protective finish to ground the integral shielding of each bushing. To assure adequate strength for apparatus support, the bushing shall withstand a minimum cantilever loading of 600 pounds for five minutes without damage. The bushing interface shall be free of all voids, holes and heat sinks to assure proper mating with separable insulated connectors. Each bushing shall be tested in free air, mounted in a grounded steel plate not less than 10 inches x 10 inches, and with an insulated bushing extension (RTE® #DBE635 or equal) installed on the interface to accurately simulate operating conditions (*gas or liquid dielectric on the interface shall not be acceptable for this test*). Each bushing shall meet the requirements for 35 kV devices in accordance with IEEE Standard 386 (latest revision), including 100 percent production testing.

Production Tests

Every bushing is production tested in free air, mounted in an 11-gauge grounded steel plate not less than 10 inches x 10 inches, with a separable insulated connector (bushing well plug, insulated protective cap and/or insulated bushing extension) installed on the interface to accurately simulate operating conditions. Each bushing must meet or exceed the requirements for 21.1/36.6 kV devices in accordance with the test values of IEEE Standard 386 (latest revision) for partial discharge (corona) and A.C. voltage withstand when tested in this manner.

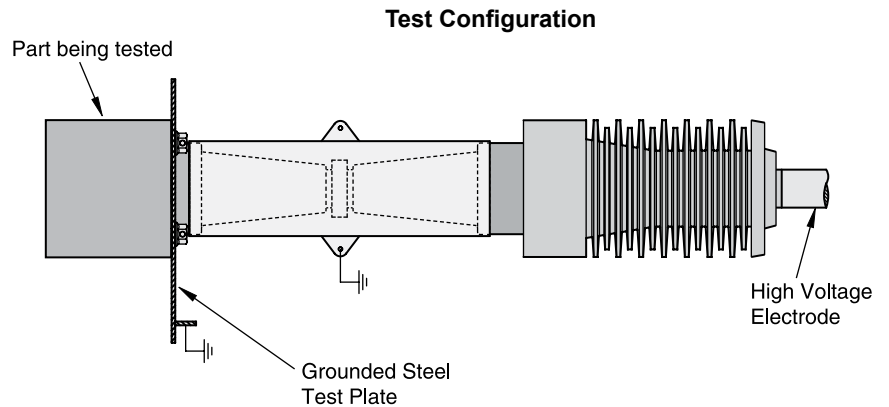

Installation Instructions

Elliott "B" Series Apparatus Bushings require a 3.125-inch diameter mounting hole with four 0.4375-inch diameter bolt holes. The bushing bolts in place utilizing four 0.375-inch - 16 x 1-inch serrated flange hex-head bolts (or bolts with external tooth lock washers).

Every Elliott Bushing is tested at the factory, mounted in a grounded steel plate. A greased separable insulated connector (bushing well plug, insulated protective cap and/or insulated bushing extension) is installed on the interface to accurately simulate operating conditions. To prevent contamination of the silicone grease, it is important to keep the shipping cap in place until you are ready to install the bushing elbow. Should the grease become contaminated, thoroughly clean the interface and reapply silicone grease before installing the bushing elbow.

NOTE: The shipping cap should be left in place to prevent contamination of the interface.

1. The bushing installs from the rear side for easy installation.

2. Serrated flange bolts (or bolts and external tooth lock washers) are installed. The bolts should be tightened in a uniform manner (rather than one-by-one in a random sequence). Do not apply more than 90 inch-pounds torque to each bolt. The serrated flange bolts (or external tooth lock washers) must "cut" into the mounting plate to provide a connection from the shielding to the grounded mounting plate. If the bushing is mounted on an ungrounded or insulated plate (such as fiberglass) a ground strap should be attached to one of the mounting bolts.

IMPORTANT:

Do not energize this bushing with only the shipping cap in place. To do so would lead to failure of the bushing and create a hazard to operating personnel. This product is designed to be used only when it is mated with an appropriate 35 kV class elbow conforming to the latest revision of IEEE Standard 386. The elbow should be installed in accordance with the instructions supplied by the connector manufacturer.

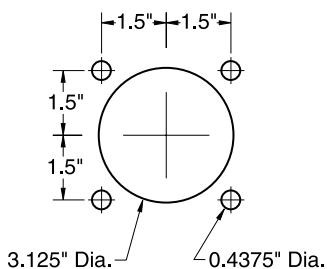

Standard Mounting Holes for Elliott "B" Series Bushings

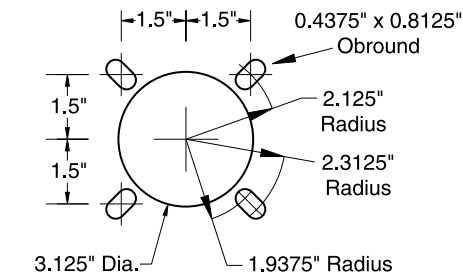

Uni-Mount Mounting Holes Accepts Elliott and S&C Bushings

