



25-kV Apparatus Bushings

“B” Series (bolt-in) for Elbow to Air Insulated Service
200 Amp Deadbreak Interface

Descriptive
Bulletin
1025-210
Page 1 2008

200 Amp Deadbreak Bushing #1141-225NB

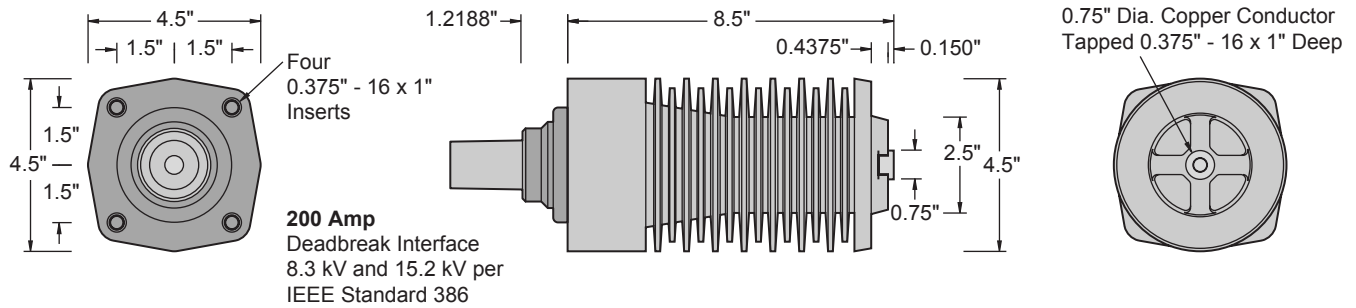

| | |
|--|--|
| <p>Voltage Class..... 25 kV Phase-to-Ground Voltage..... 15.2 kV BIL..... 125 kV A.C. Withstand - 1 Min. Dry..... 40 kV 10 Sec. Dew..... 40 kV D.C. Withstand - 15 Min. Dry..... 78 kV Corona Extinction Level - Minimum..... 19 kV Continuous Current..... 200 Amps Momentary - RMS, Sym., 0.17 sec..... 10,000 Amps RMS, Sym., 3 sec..... 3,500 Amps</p> | <p>Leakage Distance, Inches..... 34 Dry Arcing Distance, Inches..... 8.5 Mechanical - Strength Rating, Pounds Cantilever, Ultimate 2.5 inches past end..... >1,000 Tensile, Pounds..... >5,000 Torsion, Inches-Pounds (bolt breaks)..... >700 Copression, Pounds..... 20,000 Insert Thread Size..... 0.375" - 16 x 1" Conductor (live end) Thread Size..... 0.375" - 16 x 1" Net Weight, Pounds (kg)..... 6.75 (3.06)</p> |
|--|--|

Typical Specifications - 200 Amp 15-kV and 25-kV Deadbreak Bushing

Bushings shall be 200 ampere Elliott #1141-225NB, 25 kV Class (15.2 kV to ground) Air Insulated Deadbreak Bushings, 125 kV BIL, per IEEE Standard 386 Fig. 4 (200 A Deadbreak Interface, 8.3 kV and 15.2 kV) for use with either 8.3/14.4 kV or 15.2/26.3 kV separable insulated connectors (Elastimold® or other approved equal). The bushings shall be pressure-molded cycloaliphatic epoxy with a 0.75-inch diameter copper conductor on the “air insulated” side that is drilled and tapped 0.375-inch – 16UNC x 1-inch deep to provide direct connection of the bus and/or live parts. Leakage distance from the apparatus connection end of the bushing well to ground shall be not less than 30 inches to assure trouble-free operation in a wet and/or contaminated environment. Integral shielding shall be provided to eliminate partial discharge caused by off-center mounting and mounting holes that may have sharp edges or burrs. Bushings shall

mount in a 3.125-inch diameter opening and bolt in place to allow field replacement with standard tools. To assure adequate strength for apparatus support, the bushing shall withstand a minimum cantilever loading of 600 pounds for five minutes without damage. The bushing interface shall be free of all voids, holes and heat sinks to assure proper mating with separable insulated connectors. Each bushing shall be tested in free air, mounted in a grounded steel plate not less than 10 inches x 10 inches, and with a bushing interface cap (Elastimold® #K150DR or equal) installed in the well interface to accurately simulate operating conditions (*gas or liquid dielectric on the interface shall not be acceptable for this test*). Each bushing shall meet the requirements for 25 kV devices in accordance with IEEE Standard 386 (latest revision), including 100 percent production testing.

ELASTIMOLD® is a registered trademark of Elastimold, A Unit of Thomas and Betts

Production Tests

Every bushing is production tested "in air", mounted in an 11-gauge grounded steel plate not less than 10 inches x 10 inches, with an insulating protective cap installed on the interface to accurately simulate operating conditions. Each bushing must meet or exceed the requirements for 15.2/26.3 kV devices in accordance with the test values of IEEE Standard 386 (latest revision) for partial discharge (corona) and A.C. voltage withstand when tested in this manner.

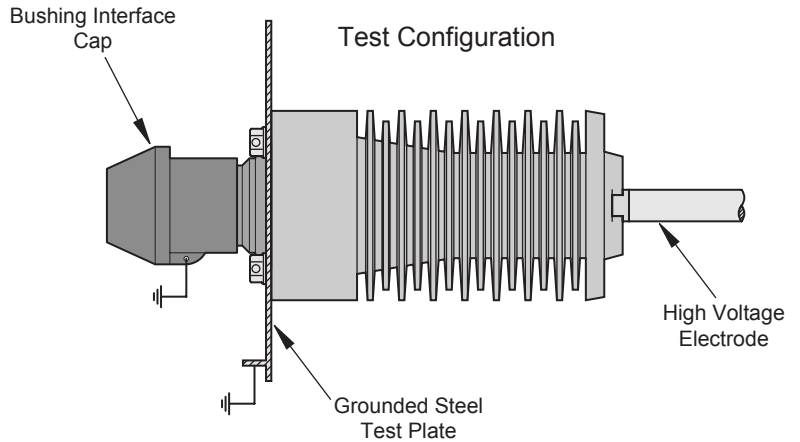

Installation Instructions

Elliott "B" Series Apparatus Bushings require a 3.125-inch diameter mounting hole with four 0.4375-inch diameter bolt holes. The bushing bolts in place utilizing four 0.375-inch - 16 x 1-inch serrated flange hex head bolts (or bolts with external tooth lock washers). All mounting hardware is located on the elbow side of the equipment mounting plate to eliminate the possibility of reduced phase-to-ground clearance.

Every Elliott Bushing is tested at the factory, mounted in a grounded steel plate. A greased insulating protective cap is installed on the interface to accurately simulate operating conditions. To prevent contamination of the silicone grease, it is important to keep the shipping cap in place until you are ready to install the bushing elbow. Should the grease become contaminated, thoroughly clean the interface and reapply silicone grease before installing the bushing elbow.

NOTE: The shipping cap should be left in place to prevent contamination of the interface.

1. The bushing installs from the rear (live) side for easy installation.
2. Serrated flange bolts (or bolts and external tooth lock washers) are installed. The bolts should be tightened in a uniform manner (rather than one-by-one in a random sequence). Do not apply more than 90 inch-pounds torque to each bolt. The serrated flange bolts (or external tooth lock washers) must "cut" into the mounting plate to provide a connection from the shielding to the grounded mounting plate. If the bushing is mounted on an ungrounded or insulated plate (such as fiberglass) a ground strap should be attached to one of the mounting bolts.

IMPORTANT:

Do not energize this bushing with only the shipping cap in place. To do so would lead to failure of the bushing and create a hazard to operating personnel. *This product is designed to be used only when it is mated with an appropriate 15 kV or 25 kV class elbow conforming to the latest revision of IEEE Standard 386.* The elbow should be installed in accordance with the instructions supplied by the connector manufacturer.

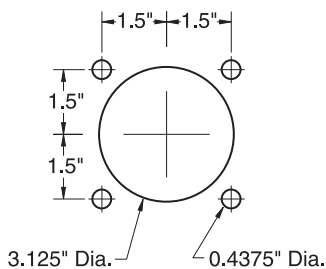

Standard Mounting Holes for Elliott "B" Series Bushings

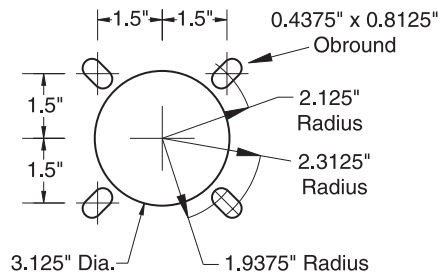

Uni-Mount Mounting Holes Accepts Elliott and S&C Bushings

