

EPM-PTS-15-311P-E6-CM5-167KVA

Three-Phase - Two Ways per Phase
 600 Amp Elliott Air Insulated Bushings
 140 Amp (Max) 8.3 kV Clip Mounted CL Fuse Provisions
 8.3/14.4 kV Grd. Wye Max Design
 60 Hertz, 95 kV BIL

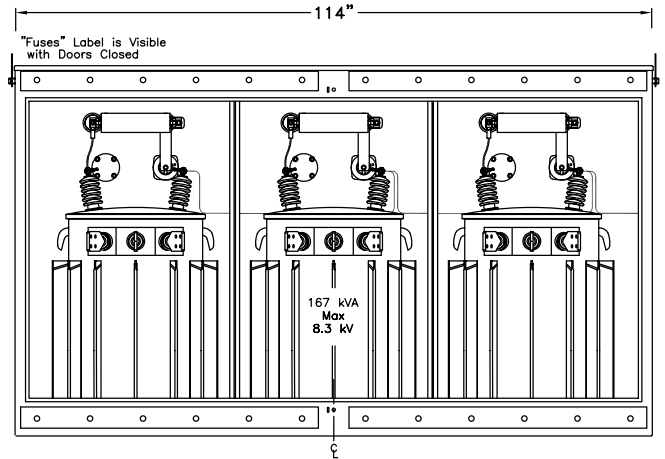

① Bushings may be added if circuit requirements change.

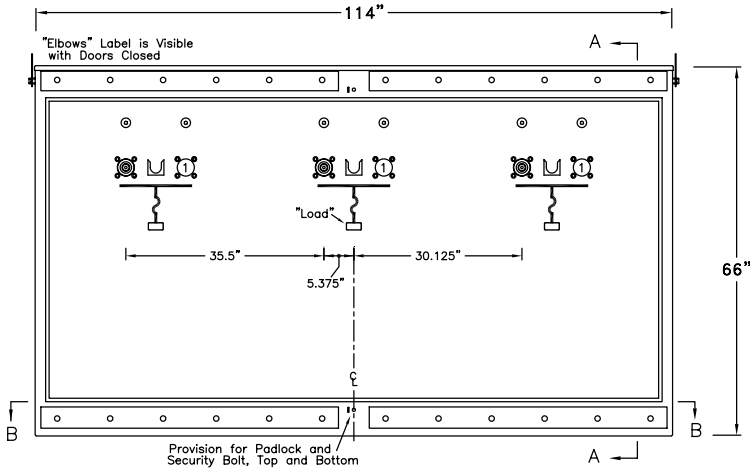
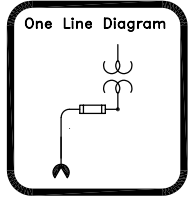
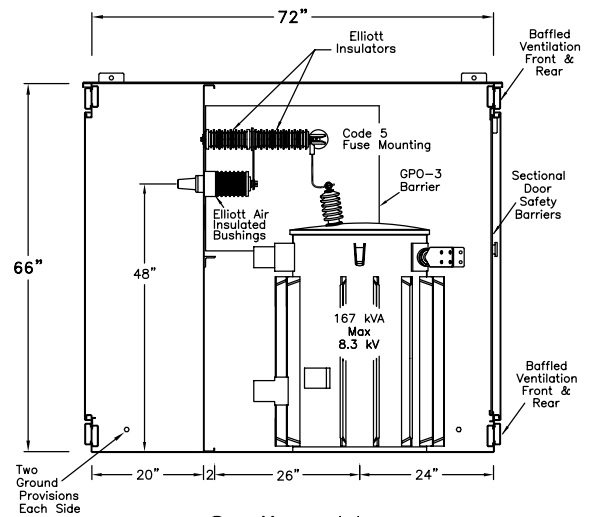
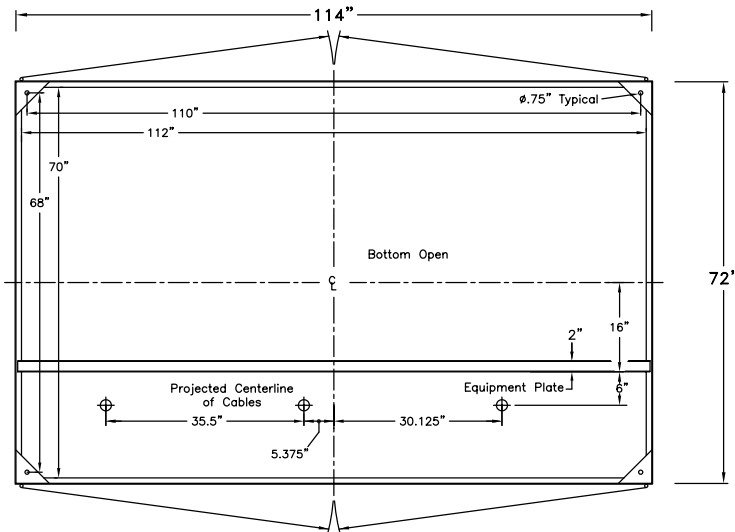

11 Gauge Steel Enclosure
 Removable Cross Kinked Top
 Stainless Steel Hinges
 Stainless Steel Parking Stands
 Recessed Stainless Steel Penta Head Security Bolts
 Clear Polycarbonate Sectional Door Safety Barriers
 6" Min Strike Distance to Ground
 8" Min Strike Distance Phase to Phase
 Paint "Pad-Mount Green" Munsell #7GY 3.29/1.5

EPM-PTS-15-311P-E6-CM5-167KVA Layout		
Date: 09-15-99	File: D99357R0	Drawing No.:
By: R.M.	Approved by: JES	99-357-1
Elliott Industries, Inc. Bossier City, Louisiana 71171-6388 U.S.A.		

EPM-PTS-15-311P-E6-CM5-167KVA

Proposed Cable Training and
Typical Pad Requirements

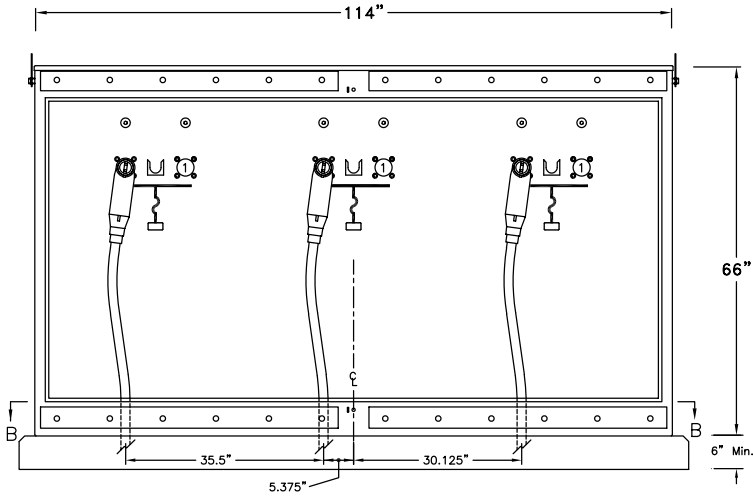
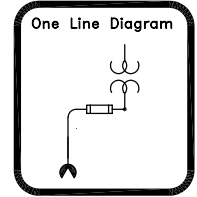

Front View
Doors Removed

① Bushings may be added if circuit requirements change.

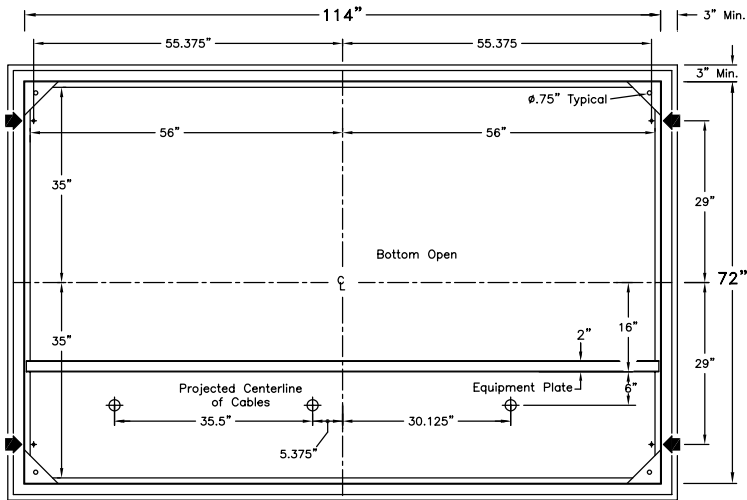
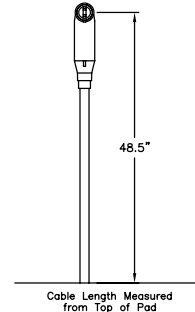

Section BB

◆ Anchor Bolt Locations

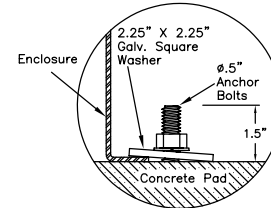

Alternate #1

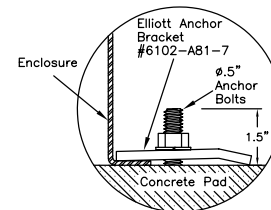

Alternate #2

EPM-PTS-15-311P-E6-CM5-167KVA		
Proposed Cable Training & Pad Requirements		
Date: 09-15-99	File: D99357R0	Drawing No.:
By: R.M.	Approved by: JES	99-357-2
Elliott Industries, Inc.		
Bossier City, Louisiana 71171-6388 U.S.A.		

EPM-PTS-15-311P-E6-CM5-167KVA

Three-Phase - Two Ways per Phase
 600 Amp Elliott Air Insulated Bushings
 140 Amp (Max) 8.3 kV Clip Mounted CL Fuse Provisions
 8.3/14.4 kV Grd. Wye Max Design
 60 Hertz, 95 kV BIL

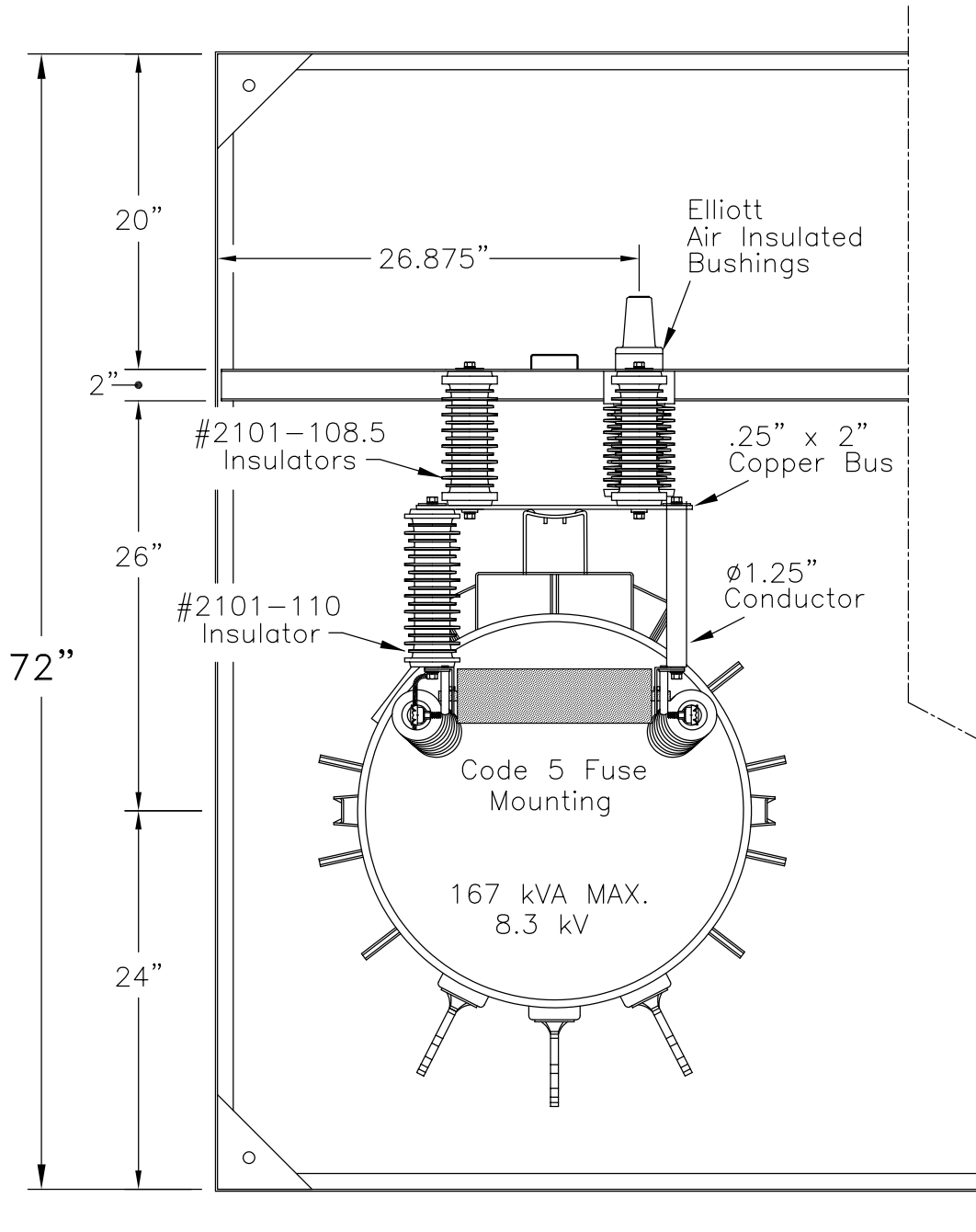
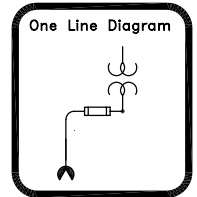

Top View of One Phase

EPM-PTS-15-311P-E6-CM5-167KVA		
Top View of One Phase		
Date: 09-15-99	File: D99357R0	Drawing No.:
By: R.M.	Approved by: JES	99-357-3
Elliott Industries, Inc.		
Bossier City, Louisiana 71171-6388 U.S.A.		