

EPM-PTS-15-321P-E6-CM5-50KVA

Three-Phase - Three Ways per Phase
 600 Amp Elliott Air Insulated Bushings
 140 Amp (Max) 8.3 kV Clip Mounted CL Fuse Provisions
 8.3/14.4 kV Grd. Wye Max Design
 60 Hertz, 95 kV BIL

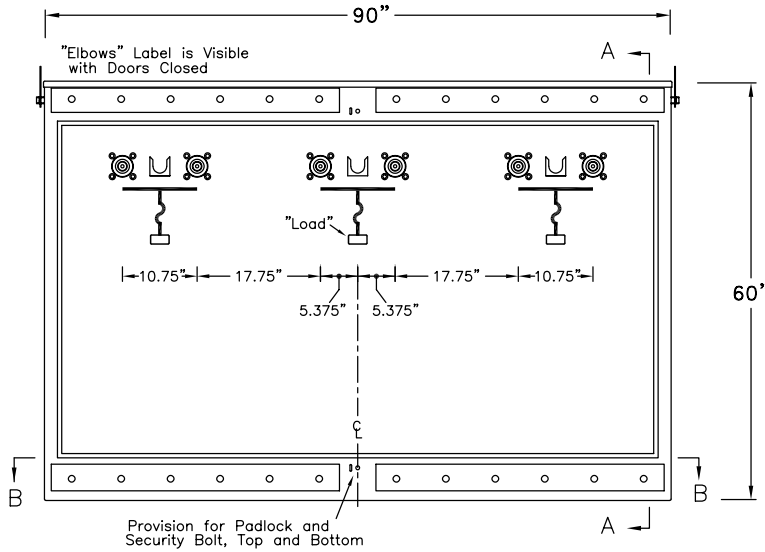

Front View
Doors Removed

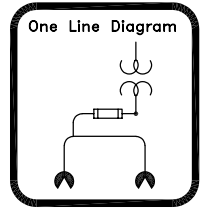
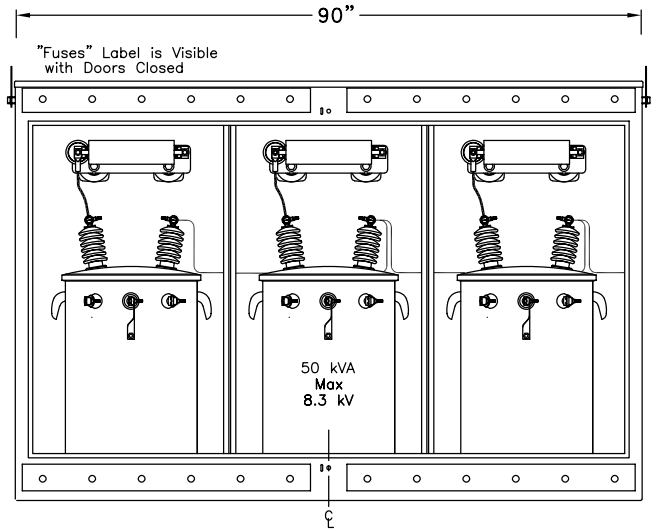

Rear View
Doors & Door Safety Barriers Removed

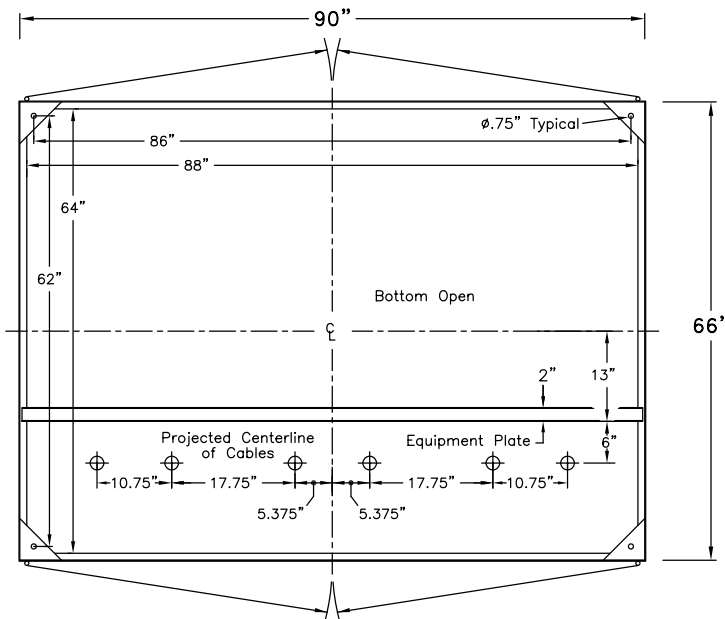

Section BB

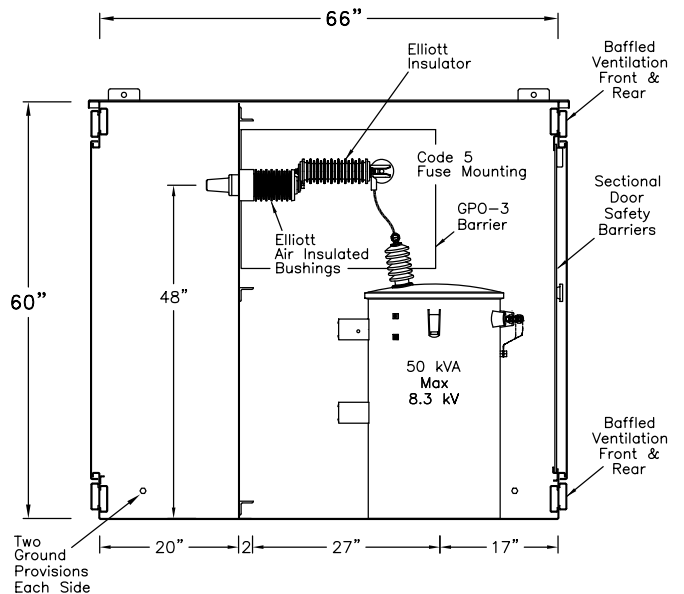

Section AA

11 Gauge Steel Enclosure
 Removable Cross Kinked Top
 Stainless Steel Hinges
 Stainless Steel Parking Stands
 Recessed Stainless Steel Penta Head Security Bolts
 Clear Polycarbonate Sectional Door Safety Barriers
 6" Min Strike Distance to Ground
 8" Min Strike Distance Phase to Phase
 Paint "Pad-Mount Green" Munsell #7GY 3.29/1.5

EPM-PTS-15-321P-E6-CM5-50KVA		
Layout		
Date: 09-09-99	File: D99356R0	Drawing No.:
By: ACM	Approved By: JES	99-356-1
Elliott Industries, Inc.		
Bossier City, Louisiana 71171-6388 U.S.A.		

EPM-PTS-15-321P-E6-CM5-50KVA

Three-Phase - Three Ways per Phase
 600 Amp Elliott Air Insulated Bushings
 140 Amp (Max) 8.3 kV Clip Mounted CL Fuse Provisions
 8.3/14.4 kV Grd. Wye Max Design
 60 Hertz, 95 kV BIL

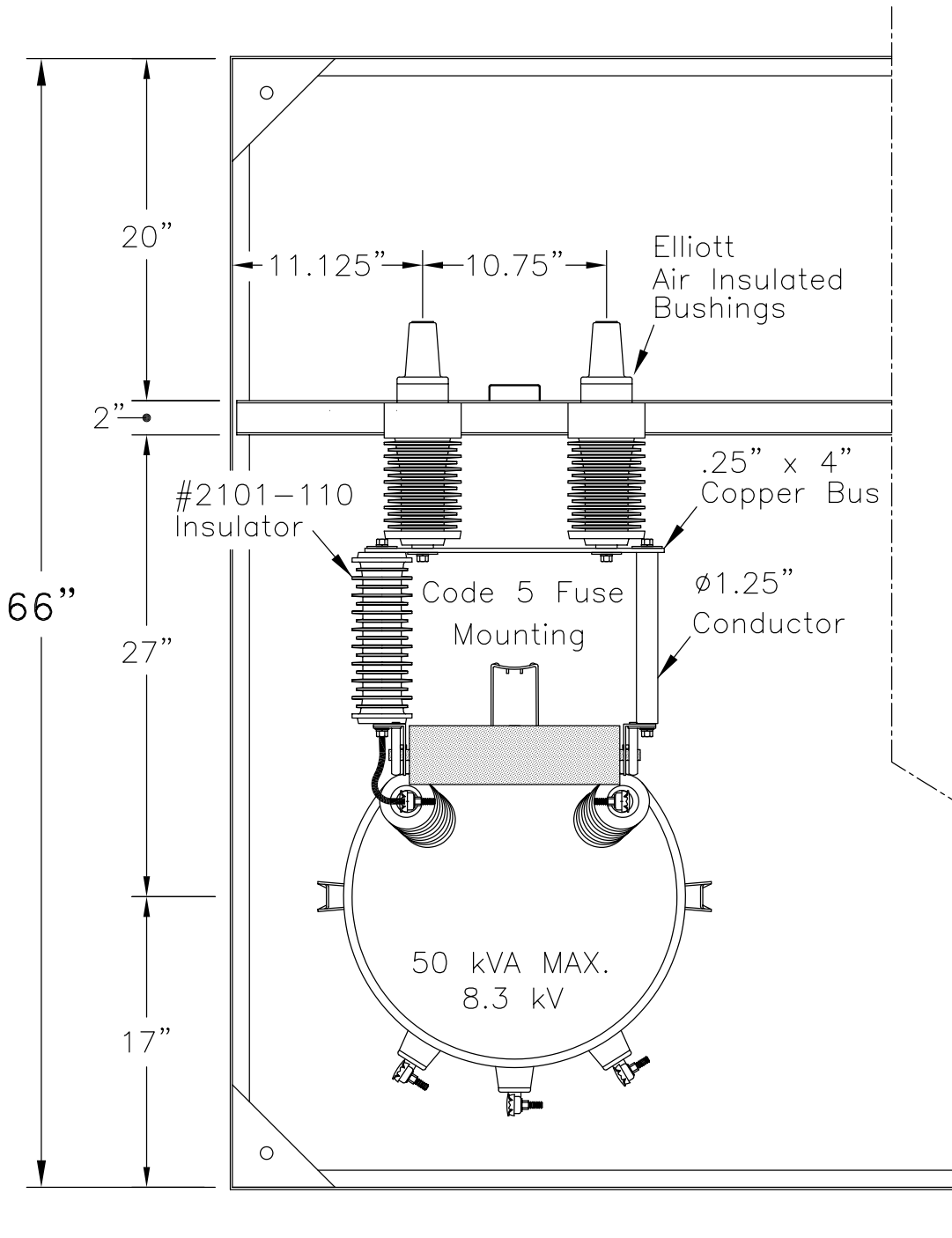
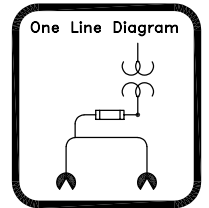

Top View of One Phase

EPM-PTS-15-321P-E6-CM5-50KVA Top View of One Phase		
Date: 09-09-99	File: D99356R0	Drawing No.:
By: ACM	Approved by: JES	99-356-3
Elliott Industries, Inc. Bossier City, Louisiana 71171-6388 U.S.A.		