

Tamper-Resistant Enclosure meets National and Regional Enclosure Integrity Standards and virtually eliminates the entrance of airborne contamination to reduce maintenance

Superlife Finish includes phosphatizing, zinc rich epoxy primer and Pad-Mount Green (Munsell 7GY 3.29/1.5) polyurethane top coat - over 5 mils dry
Optional Paint:
Grey (Munsell 5BG 7.0/0.4)

Open bottom and bus arrangement allows access to all cables for easy installation and maintenance

Corrosion-resistant nameplate is located to provide easy access for the operator

Glass reinforced barriers meet NEMA GPO-3 Standards

Bus Bar Options:

- 1) 0.25" x 6" Copper Bus
- 2) 0.25" x 6" Tin-plated Copper Bus

Enclosure Options

- 1) 0.125" #5052H32 Aluminum
- 2) 12-gauge #304L Stainless Steel

"In-Air" Insulation

eliminates leaking or contamination of insulating medium for long trouble-free operation

"In-Air" Visibility

allows visual inspection of all components without the inconvenience or expense associated with equipment which must be de-energized for inspection

Safety latches on the door safety barrier are insulating and require a positive action to remove the safety barrier

Aluminum bus bar accepts NEMA Standard 2-hole and 4-hole lugs back-to-back

Door safety barriers are clear polycarbonate

Ground lugs on each wall of the enclosure accept #6 - #2/0 ground cable

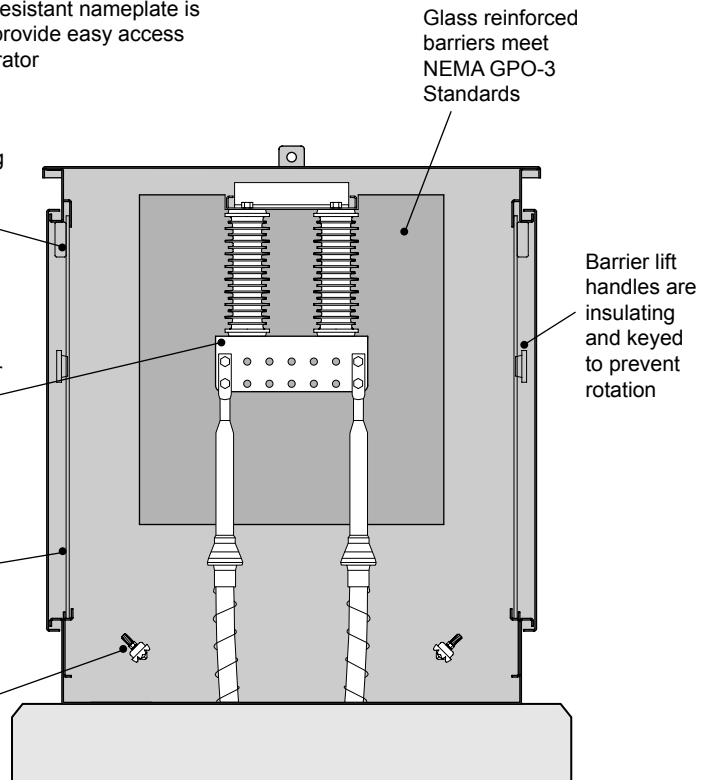



35-kV Live Terminal Cable Terminating Station

Three-Phase Pad-Mounted Outdoor

Bulletin
760-312
Page 2 2009

Three-Phase – One Way per Phase
21.1/36.6 kV Grounded Wye Max Design
150 kV BIL

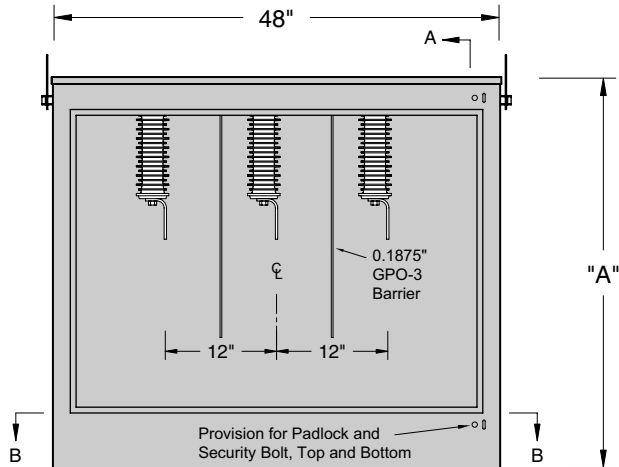

Front View
Door & Door Safety
Barrier Removed

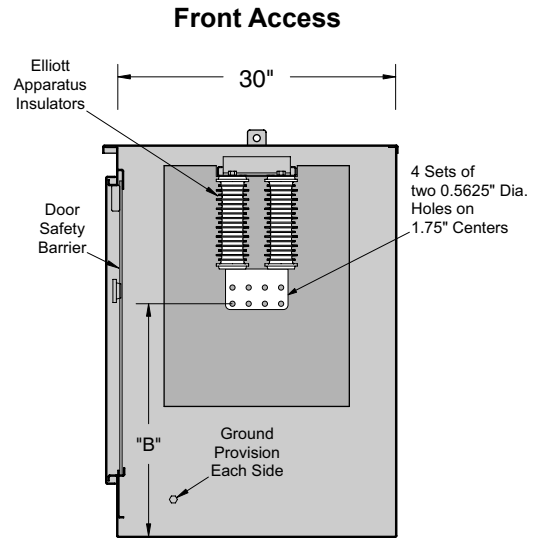

Section AA

10" Min. Strike Distance to Ground
12" Min. Strike Distance Phase-to-Phase

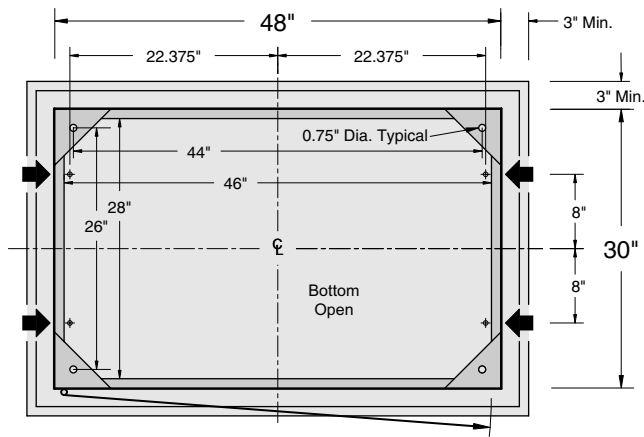

+ ← Anchor Bolt Locations

Section BB
with Typical Pad Dimensions

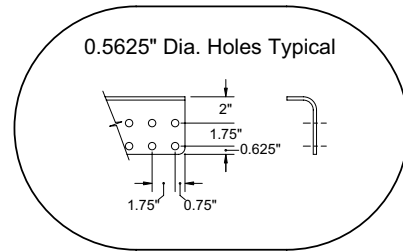

Bus Detail

Standard Bus:
Three Single 0.25" x 6" Aluminum Bus
1250/1500 Amp at 30/45 degree C rise over
40 degree C Ambient

Alternate Bus:
Three Single 0.25" x 6" Copper Bus
1500/1750 Amp at 30/45 degree C rise over
40 degree C Ambient

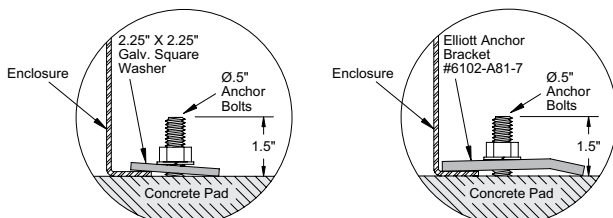

Alternate #1

Alternate #2

Anchor Bolt Detail

Catalog Number	Dim. "A"	Dim. "B"
EPM-CTSL-35-320S-LT-D8880-42H	42"	25"
EPM-CTSL-35-320S-LT-D8880-48H	48"	31"
EPM-CTSL-35-320S-LT-D8880-54H	54"	37"



35-kV Live Terminal Cable Terminating Station

Three-Phase Pad-Mounted Outdoor

Bulletin
760-312
Page 3 2009

Three-Phase – One Way per Phase
21.1/36.6 kV Grounded Wye Max Design
150 kV BIL

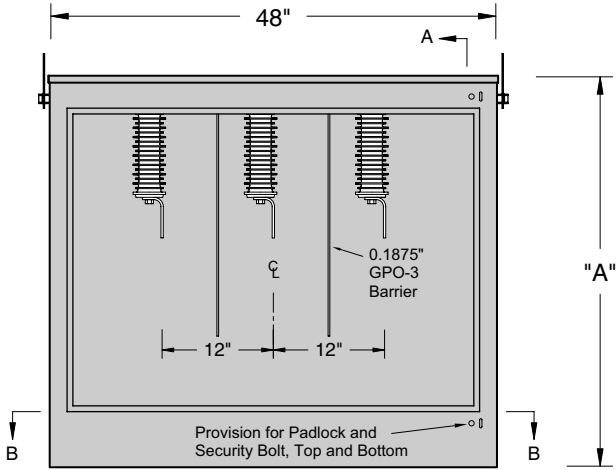

Front View
Door & Door Safety
Barrier Removed

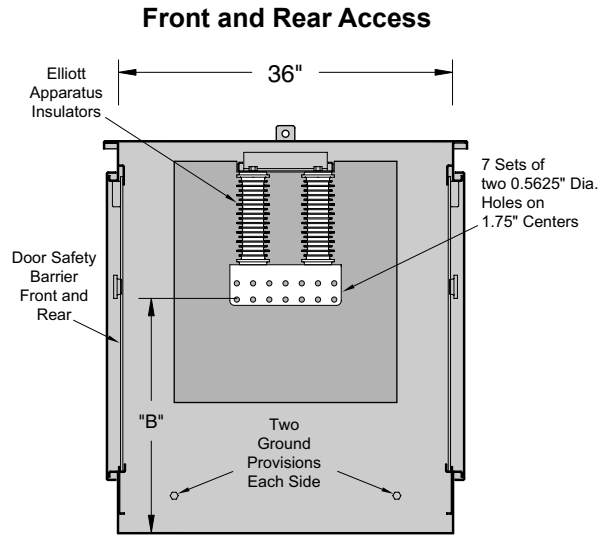

Section AA

10" Min. Strike Distance to Ground
12" Min. Strike Distance Phase-to-Phase

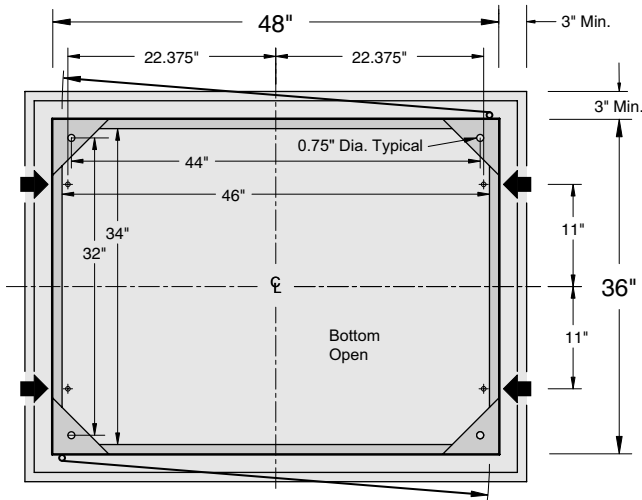

+ ◀ Anchor Bolt Locations

Section BB
with Typical Pad Dimensions

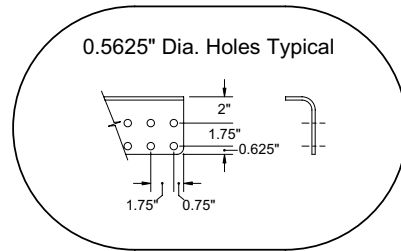

Bus Detail

Standard Bus:

Three Single 0.25" x 6" Aluminum Bus
1250/1500 Amp at 30/45 degree C rise over
40 degree C Ambient

Alternate Bus:

Three Single 0.25" x 6" Copper Bus
1500/1750 Amp at 30/45 degree C rise over
40 degree C Ambient

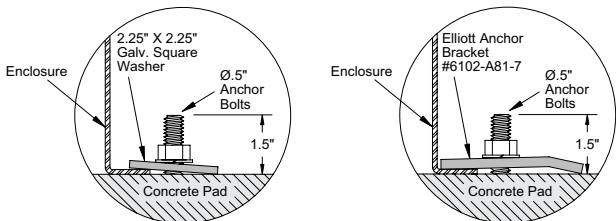

Alternate #1

Alternate #2

Anchor Bolt Detail

Catalog Number	Dim. "A"	Dim. "B"
EPM-CTSL-35-320S-LT-D8881-42H	42"	25"
EPM-CTSL-35-320S-LT-D8881-48H	48"	31"
EPM-CTSL-35-320S-LT-D8881-54H	54"	37"

Typical Specification

General

The cable terminating station shall be 35 kV class, 150 kV BIL, 1250 ampere (Alternate—1500 ampere) continuous current, suitable for use on 21.1/36.6 kV grounded wye max design systems. The cable terminating station shall be constructed for connection to the utility system with two-hole and/or four-hole NEMA Standard bolt-on cable-terminal lugs (terminal lugs shall be supplied by the user). A door safety barrier shall be provided inside the door(s) as recommended in IEEE Standard C2 (National Electrical Safety Code) Rule 381G. Tamper resistance shall meet the Enclosure Security requirements of IEEE Standard C57.12.28 (Pad-Mounted Equipment—Enclosure Integrity). Together, the tamper resistance and the door safety barrier(s) shall resist unauthorized entry, protect authorized and unauthorized persons, and provide positive safety features when installed in areas accessible to the general public. The cable terminating station shall be constructed for outdoor installation in areas subject to heavy precipitation and in areas of windblown contamination. The equipment shall be "air-insulated" and completely assembled prior to shipment.

Enclosure Construction

The enclosure shall be tamper-resistant, all-welded construction utilizing 11-gauge minimum sheet steel. Corner plates and braces shall be used as necessary to assure rigidity. The enclosure top shall be cross-kinked to provide watershed and rigidity. The enclosure shall be open bottom with a 1-inch flange inside, all around. The door(s) shall be furnished with a stainless steel door holder that will latch the door open 100 degrees and 140 degrees and resist accidental closing. Door(s) shall be provided with provisions for padlocking and a recessed penta-head (or hex-head) security bolt to prevent unauthorized entry (coordinated to prevent installation of the padlock until the security bolt is tightened *when closing the door(s)*) and to prevent a wrench from operating the security bolt until the padlock is removed *when opening the door(s)*). The security bolt shall be made captive with a stainless steel washer compressed to an oval shape to severely discourage removal. Hinges shall be stainless steel (with stainless steel pins not less than 0.3125-inch diameter) and shall be welded to both the enclosure and the door(s) to maintain door alignment for the life of the equipment. The enclosure shall be nonventilated to minimize the entrance of airborne contamination, insects, rodents or reptiles. The protective finish shall include necessary grinding, 5-stage cleaning and phosphatizing, two-component rust-inhibiting zinc rich epoxy primer and a Pad-Mount Green two-component polyurethane top coat finish (Munsell color 7GY 3.29/1.5). The primer and top coat shall be electronically monitored during application to insure proper ratio and mixing of each component. Total average thickness of paint (after curing) shall be not less than 5 mils. The protective coating shall meet the Enclosure Coating System requirements of IEEE Standard C57.12.28 (Pad-Mounted Equipment—Enclosure Integrity). Removable lift provisions, adequate to withstand handling with normal utility equipment, shall be provided on the outside of the enclosure. Threaded openings for lift provision bolts shall be blind holes to prevent the entrance of wire or other foreign objects into the enclosure when lift provisions are removed.

Bus and Bus Mountings

Bus shall be aluminum (Alternate #1—bare copper, Alternate #2—tin-plated copper) with all burrs and sharp corners removed prior to installation. It shall be punched with 4 sets or 7 sets (Alternate—specify number) of two 0.5625-inch diameter holes on 1.75-inch

centers to accommodate both two-hole and four-hole NEMA Standard cable-terminal lugs. A minimum of two insulators shall be provided for each bus. The insulators shall be cycloaliphatic epoxy and shall be mounted in a manner that will allow field replacement with standard tools without removal of cables that may be bolted to the bus. Insulators and bus bars shall be installed with stainless steel mounting hardware to provide long life and reduced maintenance. All components shall be arranged to allow visual inspection without de-energizing or removing the equipment from service.

Barriers

Phase and ground barriers shall be provided to assure correct phase-to-phase and phase-to-ground clearances for proper operation at rated voltage. These barriers shall be glass-reinforced polyester (NEMA GPO-3 class material) not less than 0.1875-inch thick.

A removable insulating barrier with a "DANGER – Keep Out! – Hazardous voltage" sign, Elliott #7203-D2003-309, shall be located inside the door(s) as recommended in Rule 381G of IEEE Standard C2 (National Electrical Safety Code). The door safety barriers shall be constructed of 0.25-inch clear polycarbonate (Lexan or equal) and *shall completely close the door opening* and be provided with a non-conductive safety latch requiring a positive action to remove the barrier. Handles and other hardware extending through this door safety barrier shall be nonconductive material. Handles shall be keyed to prevent rotation for secure handling. *Complete visual inspection of the internal components shall be possible without removing the door safety barrier.*

Grounding Provisions

Two high-conductivity bronze eyebolt-type ground lugs, which accept #6 through #2/0 copper conductor, shall be installed in the cable terminating compartment (located on each side of the door opening in an accessible position).

Accessory Equipment

An anodized aluminum nameplate shall be installed inside one enclosure door. It shall be located at the top corner farthest from the enclosure when the door is open. The nameplate will provide Type of Equipment, Model Number, Amps Continuous, kV Maximum, BIL, Serial Number, Date Manufactured and Weight of Equipment.

When specified, four anchor-bolt brackets, Elliott #6102-A81-7 or approved equal, shall be supplied with each cable terminating station to provide a means of clamping the equipment to the concrete pad.

When specified, one "Warning - Keep Out! - Hazardous Voltage" sign, Elliott #7201-W2003-316, shall be provided on the exterior of each door.

Packaging

Each cable terminating station shall be bolted to a solid-top wood pallet (to prevent the forks of a forklift truck from entering the open bottom of the equipment) to prevent hidden damage. The equipment shall be wrapped with 0.125-inch thick polyethylene foam or other suitable material to minimize damage to the finish during shipment.

Drawings

When specified, drawings shall be furnished for each cable terminating station that include:

- 1) enclosure dimensions and location of components.
- 2) proposed cable-training layout and dimensions.
- 3) proposed pad dimensions and location of anchor bolts.