

Three Phase – One Way per Phase
200 Amp Elliott Air-Insulated Bushing Wells
40 Amp (Max) 15.5 kV Clip-Mounted CL Fuse Provisions
15.2/26.3 kV Grounded Wye Max Design
125 kV BIL

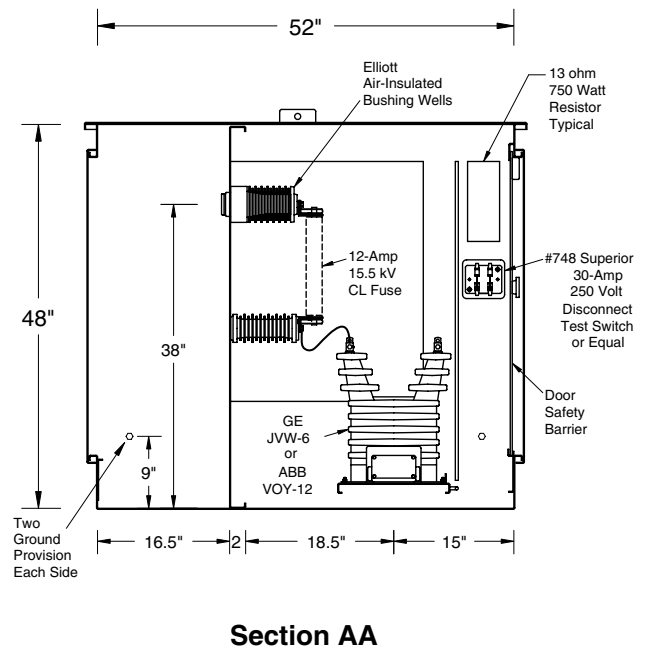

EPM-GFSS-25-310S-E2-CM5

NEMA Standard Outdoor
Voltage Transformers

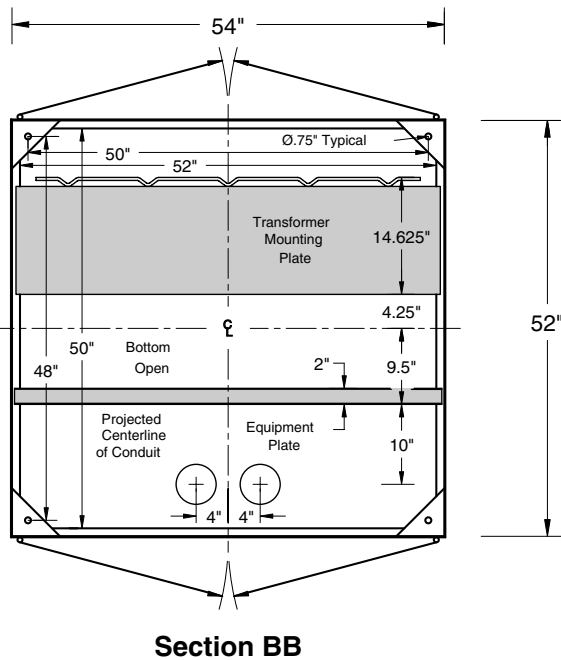
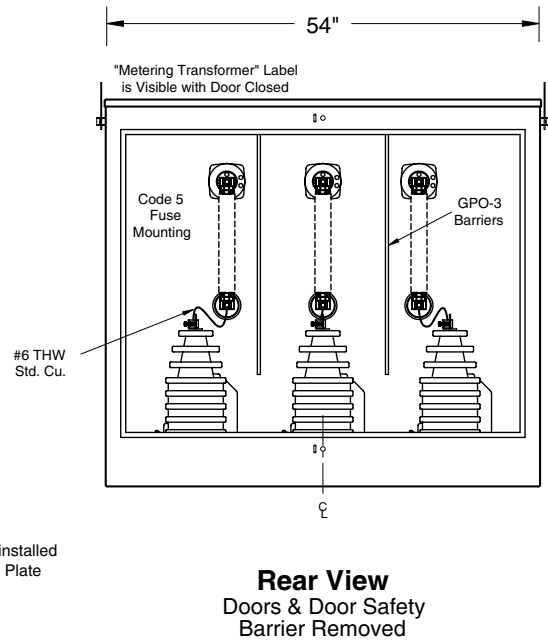
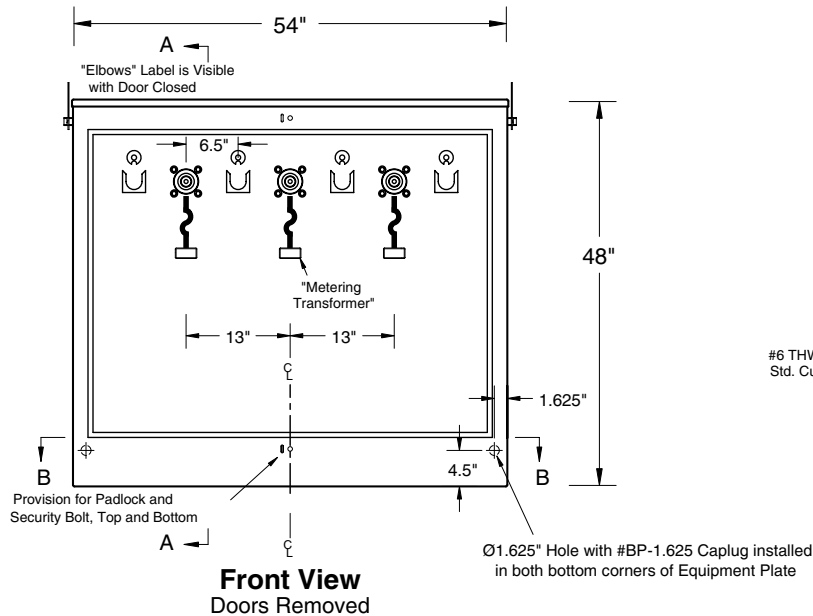

25-kV Safefront Ground Fault Sensing Station

200-Amp Pad-Mounted Outdoor

Bulletin
560-202
Page 2 2009

Cable Training and Anchor Bolt Locations

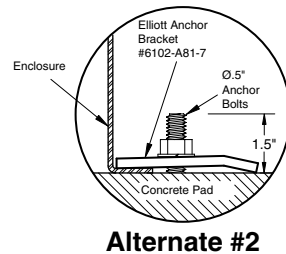
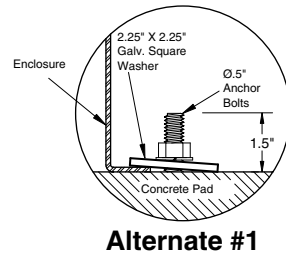
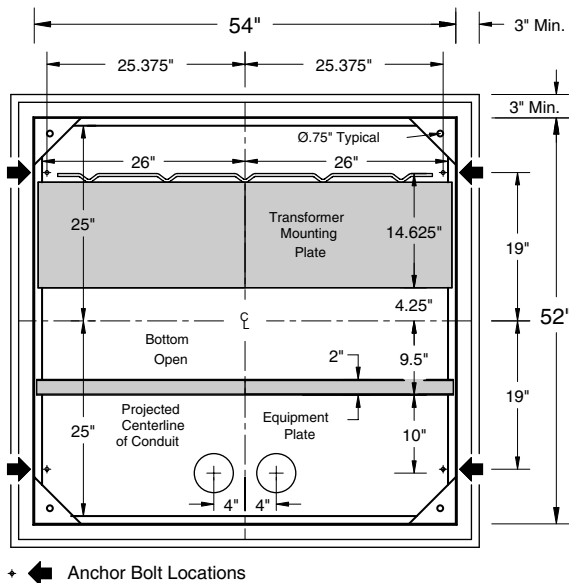
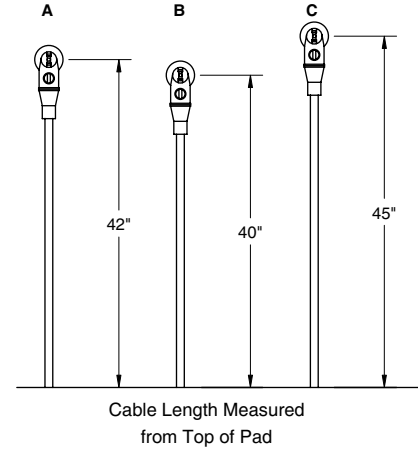
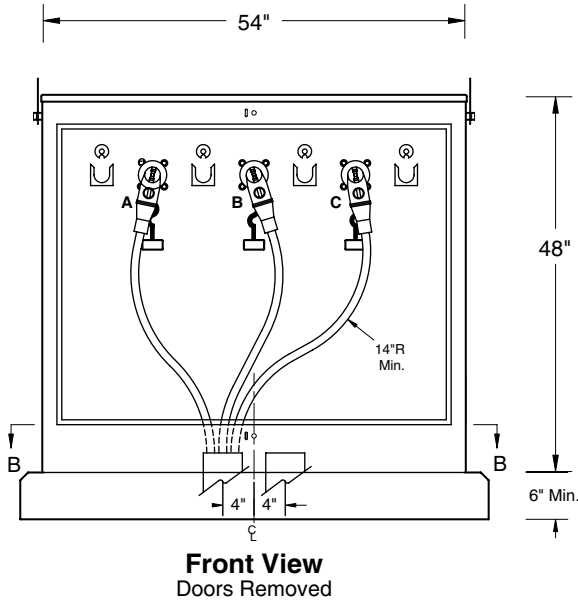

EPM-GFSS-25-310S-E2-CM5	NEMA Standard Outdoor Voltage Transformers
--------------------------------	---

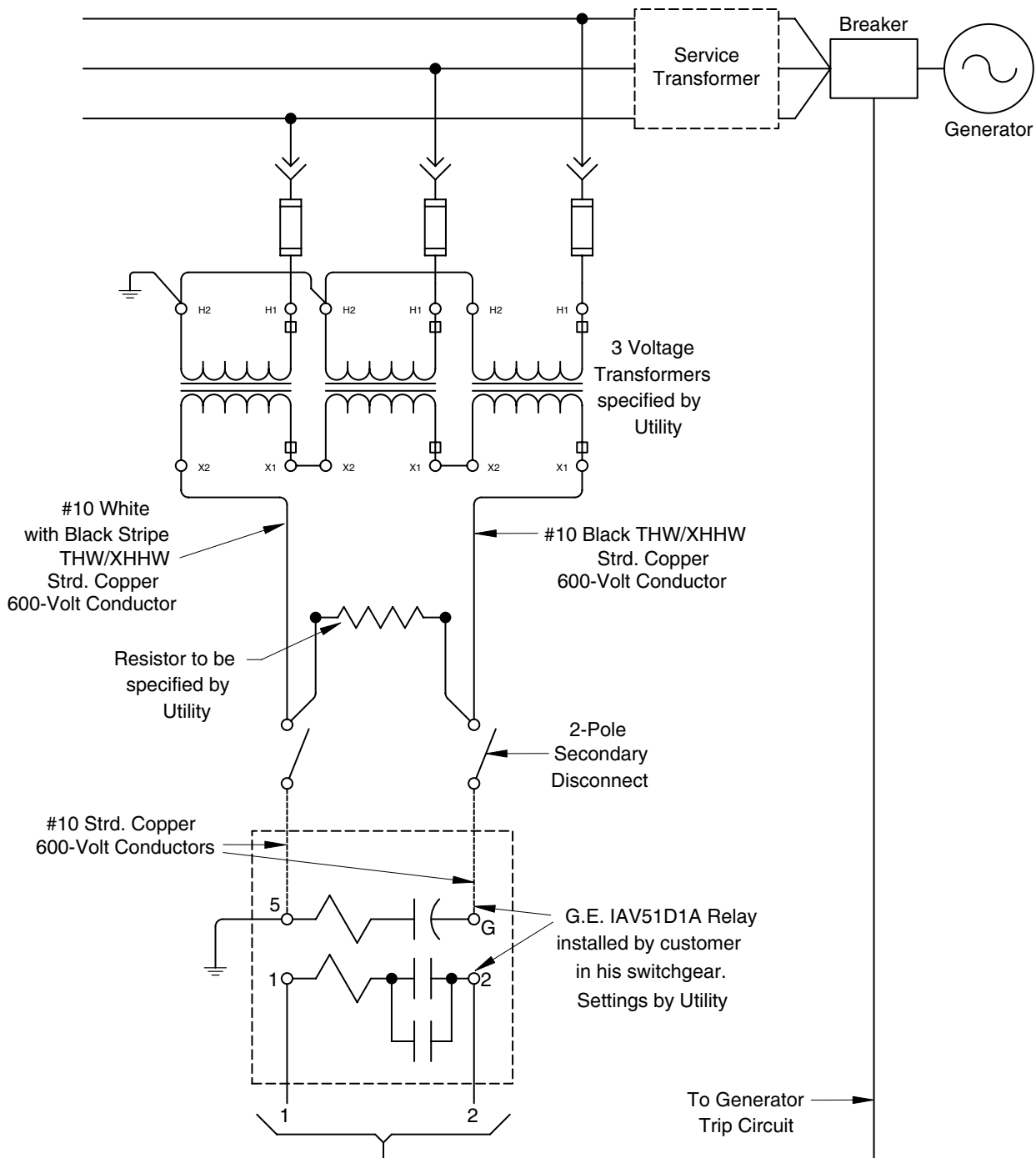

**Typical
Broken-Delta
Voltage Sensing**



25-kV Safefront Ground Fault Sensing Station

200-Amp Pad-Mounted Outdoor

Bulletin
560-202
Page 4 2009

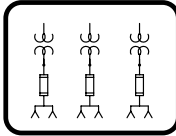

Three Phase – Two Ways per Phase
 200 Amp Elliott Air-Insulated Bushing Wells
 40 Amp (Max) 15.5 kV Clip-Mounted CL Fuse Provisions
 15.2/26.3 kV Grounded Wye Max Design
 125 kV BIL

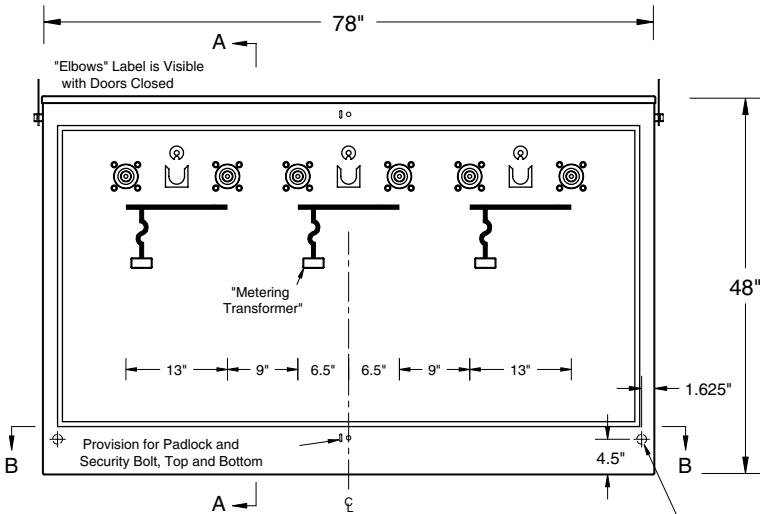

Front View
Doors Removed

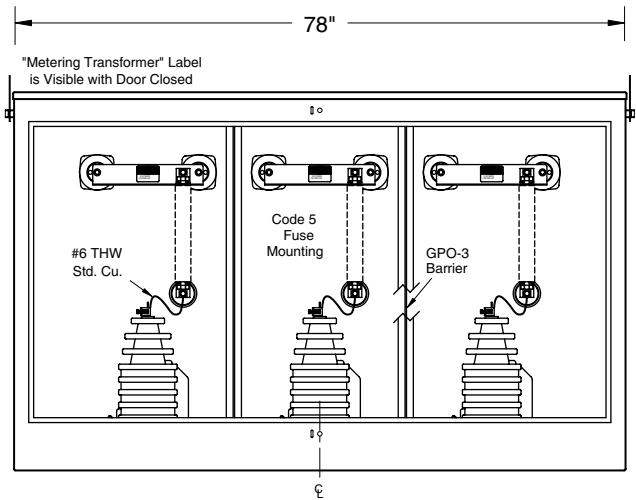

Rear View
Doors & Door Safety Barriers Removed

Ø1.625" Hole with #BP-1.625 Caplug installed in both bottom corners of Equipment Plate

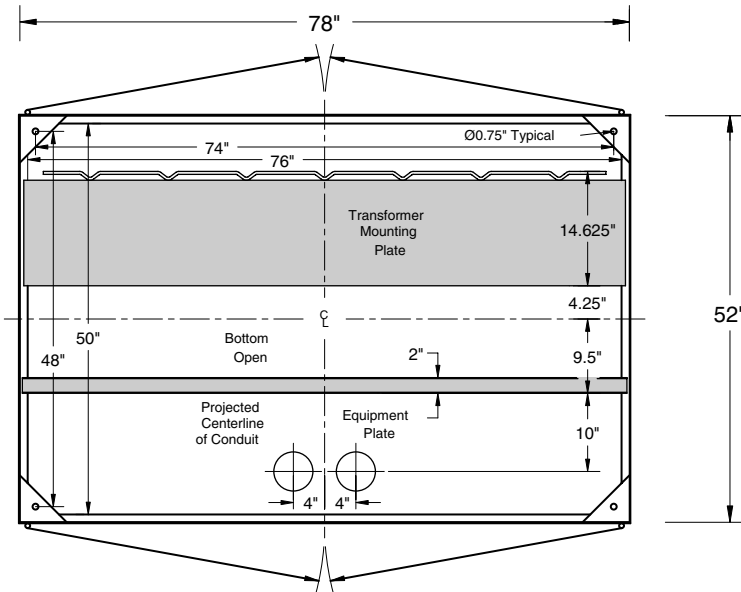

Section BB

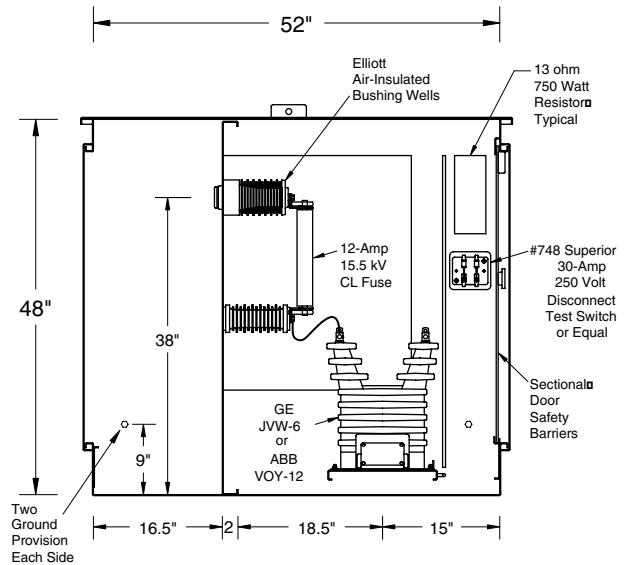

Section AA

EPM-GFSS-25-320S-E2-CM5

NEMA Standard Outdoor Voltage Transformers



25-kV Safefront Ground Fault Sensing Station

200-Amp Pad-Mounted Outdoor

Bulletin
560-202
Page 5 2009

Cable Training and Anchor Bolt Locations

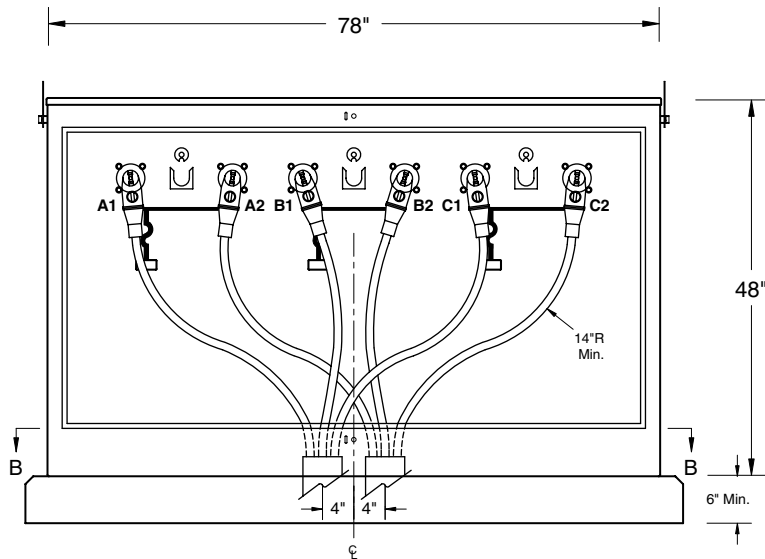

Front View
Doors Removed

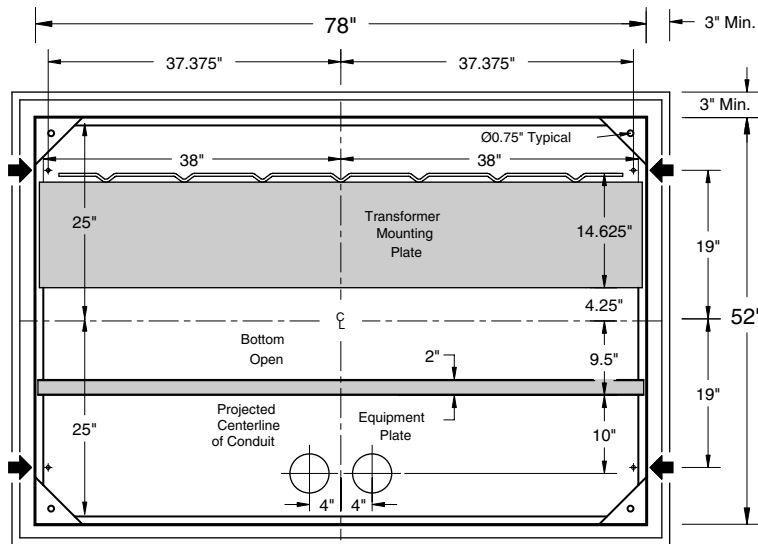
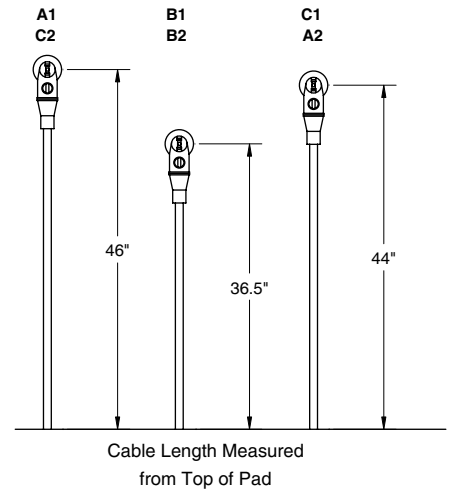

➔ ➔ Anchor Bolt Locations

Section BB
and Typical Pad Dimensions

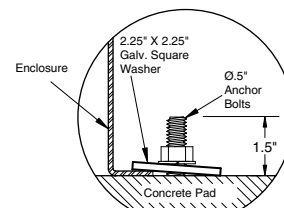

Alternate #1

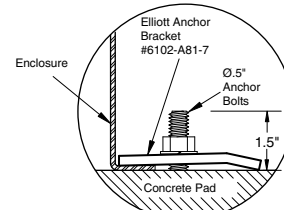

Alternate #2

EPM-GFSS-25-320S-E2-CM5

NEMA Standard Outdoor
Voltage Transformers



25-kV Safefront Ground Fault Sensing Station

200-Amp Pad-Mounted Outdoor

Bulletin
560-202
Page 6 2009

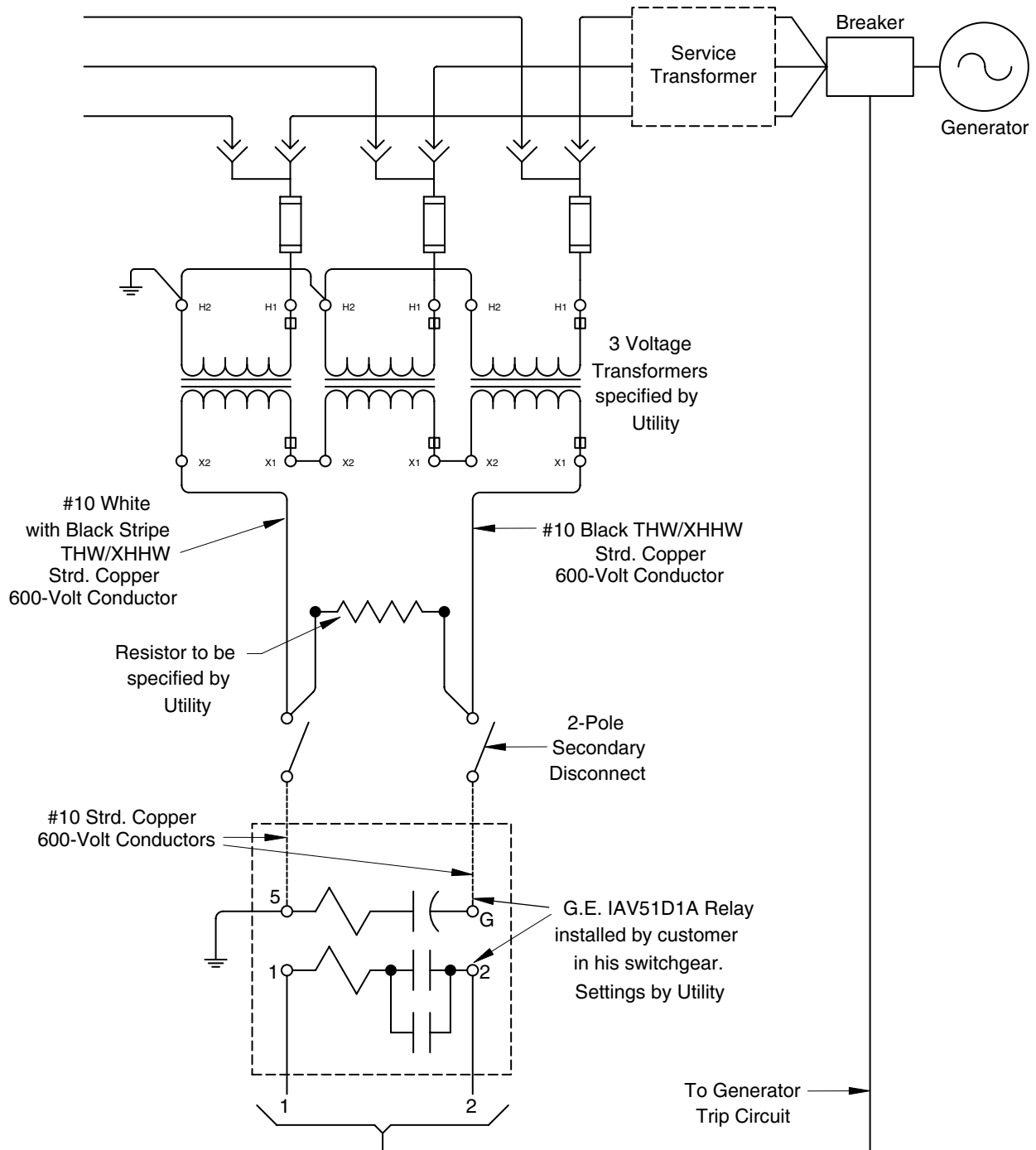

Typical Broken-Delta Voltage Sensing



25-kV Safefront Ground Fault Sensing Station

200-Amp Pad-Mounted Outdoor

Bulletin
560-202
Page 7 2009

Typical Specification - Page 1 of 2

General

The ground fault sensing station shall be 25 kV class, 125 kV BIL, 200 ampere continuous current, suitable for use on 15.2/26.3 kV grounded wye max design systems. The ground fault sensing station shall be constructed for connection to the utility system with loadbreak separable insulated connectors as described in IEEE Standard 386—latest revision (separable insulated connectors and loadbreak inserts shall be supplied by the user). The sensing station shall be designed for and contain (or accept) standard outdoor voltage transformers in a compartment separated from the elbow compartment by a steel equipment plate. Separate access shall be provided for each compartment. A door safety barrier shall be provided inside the door(s) on the voltage transformer compartment as recommended in IEEE Standard C2 (National Electrical Safety Code) Rule 381G. Tamper resistance shall meet the Enclosure Security requirements of IEEE Standard C57.12.28 (Pad-Mounted Equipment—Enclosure Integrity). Together, the tamper resistance and the door safety barrier shall resist unauthorized entry, protect authorized and unauthorized persons, and provide positive safety features when installed in areas accessible to the general public. The ground fault sensing station shall be constructed for outdoor installation in areas subject to heavy precipitation and in areas with windblown contamination. The equipment shall be “air-insulated” and completely assembled prior to shipment.

Enclosure Construction

The enclosure shall be tamper-resistant, all-welded construction utilizing 11-gauge minimum sheet steel. Corner plates and braces shall be used as necessary to assure rigidity. The enclosure top shall be cross-kinked to provide watershed and rigidity. The enclosure shall be open bottom with a 1-inch flange inside, all around. Separate compartments shall be provided for cable termination and for voltage transformers—each compartment equipped with its own individual access door(s) furnished with a stainless-steel door holder that will latch the door open 100 degrees and 140 degrees and resist accidental closing. The equipment plate separating the two compartments shall be full length, constructed with 11-gauge minimum sheet steel braced to assure rigidity when operating the elbows. Doors shall be provided with provisions for padlocking and a recessed penta-head (or hex-head) security bolt to prevent unauthorized entry (coordinated to prevent installation of the padlock until the security bolt is tightened *when closing the door(s)* and to prevent a wrench from operating the security bolt until the padlock is removed *when opening the door(s)*). The security bolt shall be made captive with a stainless steel washer compressed to an oval shape to severely discourage removal. Hinges shall be stainless steel (with stainless steel pins not less than 0.3125-inch diameter) and shall be welded to both the enclosure and the door to maintain door alignment for the life of the equipment. Voltage transformer mounting plates shall be constructed with 11-gauge minimum sheet steel formed and reinforced to provide proper support for voltage transformers installed (or to be installed) thereon. The mounting plates shall be punched with a pattern of holes that accept installation of all NEMA standard outdoor voltage transformers without the need to punch or drill additional holes. The pattern of holes shall be located to

place the voltage transformers in a position that provides proper electrical clearance. A 0.375-inch diameter cable-lacing rod shall be welded to the front edge of each transformer mounting plate and to both inside walls of the voltage transformer compartment (with stand-off clearance of 0.75-inch) to provide support for secondary wiring to be user (or factory) installed. The enclosure shall be nonventilated to minimize the entrance of airborne contamination, insects, rodents or reptiles. The protective finish shall include necessary grinding, 5-stage cleaning and phosphatizing, two-component rust-inhibiting zinc rich epoxy primer and a Pad-Mount Green two-component polyurethane top coat finish (Munsell color 7GY 3.29/1.5). The primer and top coat shall be electronically monitored during application to insure proper ratio and mixing of each component. Total average thickness of paint (after curing) shall be not less than 5 mils. The protective coating shall meet the Enclosure Coating System requirements of IEEE Standard C57.12.28 (Pad-Mounted Equipment—Enclosure Integrity). Removable lift provisions, adequate to withstand handling with normal utility equipment, shall be provided on the outside of the enclosure. Threaded openings for lift provision bolts shall be blind holes to prevent the entrance of wire or other foreign objects into the enclosure when lift provisions are removed.

Bushings and Terminals

Bushings shall be 200 ampere Elliott #1101-225B, 25 kV class (15.2 kV to ground) Air-Insulated Bushing Wells, 125 kV BIL, per IEEE Standard 386 Fig. 3 (200 A Bushing Well Interface, 8.3 kV, 15.2 kV and 21.1 kV) *for use with either 8.3/14.4 kV or 15.2/26.3 kV separable insulated connectors* (Elastimold®, Cooper Power Systems [RTE®] or other approved equal). The bushing wells shall be pressure-molded cycloaliphatic epoxy with a 0.75-inch diameter copper conductor on the “air-insulated” side that is drilled and tapped 0.375-inch – 16UNC x 1-inch deep to provide direct connection of the bus and/or live parts. Leakage distance from the apparatus connection end of the bushing well to ground shall be not less than 30-inches to assure trouble-free operation in a wet and/or contaminated environment. Integral shielding shall be provided to eliminate partial discharge caused by off-center mounting and mounting holes that may have sharp edges or burrs. Bushing wells shall mount in a 3.125-inch diameter opening and bolt in place to allow field replacement with standard tools. The bushing mounting bolts shall be self-locking stainless steel serrated-flange hex-head bolts that cut through the enclosure protective finish to ground the integral shielding of each bushing. The head of one or more of the mounting bolts for each bushing shall include a 0.156-inch diameter hole to provide a connection to ground for the loadbreak insert shielding ground wire as recommended by separable insulated connector manufacturers. To assure adequate strength for apparatus support, the bushing well shall withstand a minimum cantilever loading of 600 pounds for five minutes without damage. The bushing well interface shall be free of all voids, holes and heat sinks to assure proper mating with separable insulated connectors. Each bushing well shall be tested in free air, mounted in a grounded steel plate not less than 10 inches x 10 inches, and with a bushing well plug (RTE® #IBWP225 or equal) installed in the well interface to



25-kV Safefront Ground Fault Sensing Station

200-Amp Pad-Mounted Outdoor

Bulletin
560-202
Page 8 2009

Typical Specification - Page 2 of 2

accurately simulate operating conditions (*gas or liquid dielectric in the interface shall not be acceptable for this test*). Each bushing well shall meet the requirements for 25 kV devices in accordance with IEEE Standard 386 (latest revision), including 100 percent production testing.

Bus and Fuse Mountings

Bus shall be copper with all burrs and sharp corners removed prior to installation. Fuse clips and/or fuse hinges shall be keyed to prevent rotation and to maintain alignment. Positive pressure shall be assured by use of stainless steel fasteners and lock washers or compression washers at all connection points. All connections shall provide direct contact of current-carrying parts and shall not depend on current transfer through fastener thread-to-thread contact. Fuses and their blown-fuse indicators shall be visible (*when the fuse compartment door(s) are open*) without removal of the clear-polycarbonate door safety barrier to allow easy identification of blown fuses without de-energizing or removing the fuse from service. Electrical components shall be "air-insulated" and positioned to allow visual inspection of all internal connections and components *without removing the clear-polycarbonate door safety barrier*, de-energizing or removing the equipment from service.

Fuse mountings shall be Mounting Code 5 to accept 1.5 amp to 40 amp (max), 15.5 kV Cooper Power Systems (McGraw-Edison) NX® and 6 amp to 40 amp (max), 15.5 kV Cooper Power Systems X-Limiter™ clip-mounted current-limiting fuses. A Warning Sign, Elliott #7201-W2003-318, shall be provided inside the fuse compartment door(s) to warn the operator to "Park the load side cable before installing or removing fuses." A Danger Sign, Elliott #7203-D2003-313, shall be provided in a prominent location near the fuse clips to warn the operator "Do not remove fuse under load." Spare fuse storage is optional. When specified, a spare fuse holder shall be provided that will allow storage (and retrieval) of Code 5 fuses with hot-line tools. Spare fuse storage shall not interfere with opening or closing the doors.

Barriers

Phase and ground barriers shall be provided to assure correct phase-to-phase and phase-to-ground clearances for proper operation at rated voltage. These barriers shall be glass-reinforced polyester (NEMA GPO-3 class material) not less than 0.1875-inch thick.

A removable insulating barrier with a "DANGER – Keep Out! – Hazardous voltage" sign, Elliott #7203-D2003-309, shall be located inside the door(s) on the transformer compartment as recommended in Rule 381G of IEEE Standard C2 (National Electrical Safety Code). This door safety barrier shall be constructed of 0.25-inch clear polycarbonate (Lexan or equal) and *shall completely close the door opening* and be provided with a nonconductive safety latch requiring a positive action to remove the barrier. Handles and other hardware extending through this door safety barrier shall be nonconductive material. Handles shall be keyed to prevent rotation for secure handling. *Complete visual inspection of the internal components shall be possible without removing the door safety barrier.*

Grounding Provisions

Four high-conductivity bronze eyebolt-type ground lugs, which accept #6 through #2/0 copper conductor, shall be installed—two in the cable terminating compartment and two in the transformer compartment—on each side of the door opening in an accessible position (as shown on the drawings).

Accessory Equipment

Stainless steel parking stands shall be provided in the quantity required to allow use of feed-thru bushings, parking bushings and grounding bushings. The parking stands shall be welded in place, in a position to allow the use of hot-line tools for installation of feed thru-bushings, etc. The parking stands shall be *unpainted* (except welds shall be painted) *to provide a ground* for feed-thru bushings and other devices that may be placed into the parking stands. *Keyed retainers* shall be welded above each parking stand *to prevent slipping or accidental removal* of portable devices such as feed-thru bushings, etc.

An anodized aluminum nameplate shall be installed inside one door on the elbow compartment. It shall be located at the top corner farthest from the elbows when the door is open. The nameplate will provide Type of Equipment, Model Number, Amps Continuous, kV Maximum, BIL, Serial Number, Date Manufactured and Weight of Equipment.

Bushing well, fuse, bus and voltage transformer connections shall be displayed (on the cable side of the equipment plate) using 0.5-inch-wide solid orange-color pressure-sensitive vinyl tape. The resulting schematic shall clearly indicate the circuit arrangement of the ground fault sensing station. The schematic shall be legible at a distance of six feet or more.

When enclosures have more than one door (or other access provision) each access shall be labeled in near proximity of the locking provisions with a pressure-sensitive vinyl label using letters not less than 0.375-inch nor more than 0.625-inch high. The label shall indicate the type of equipment behind the access (elbows, transformers, etc.).

When specified, four anchor-bolt brackets, Elliott #6102-A81-7 or approved equal, shall be supplied with each sensing station to provide a means of clamping the equipment to the concrete pad.

Packaging

Each sensing station shall be bolted to a solid-top wood pallet (to prevent the forks of a forklift truck from entering the open bottom of the equipment) to prevent hidden damage. The equipment shall be wrapped with 0.125-inch thick polyethylene foam or other suitable material to minimize damage to the finish during shipment.

Drawings

When specified, drawings shall be furnished for each sensing station that include:

- 1) enclosure dimensions and location of components.
- 2) proposed cable-training layout and dimensions.
- 3) proposed pad dimensions and location of anchor bolts.