

# 25-kV Wall-Mount Switchgear 600 Amp S&C Mini-Rupter® Switch

Three Phase – Indoor/Outdoor

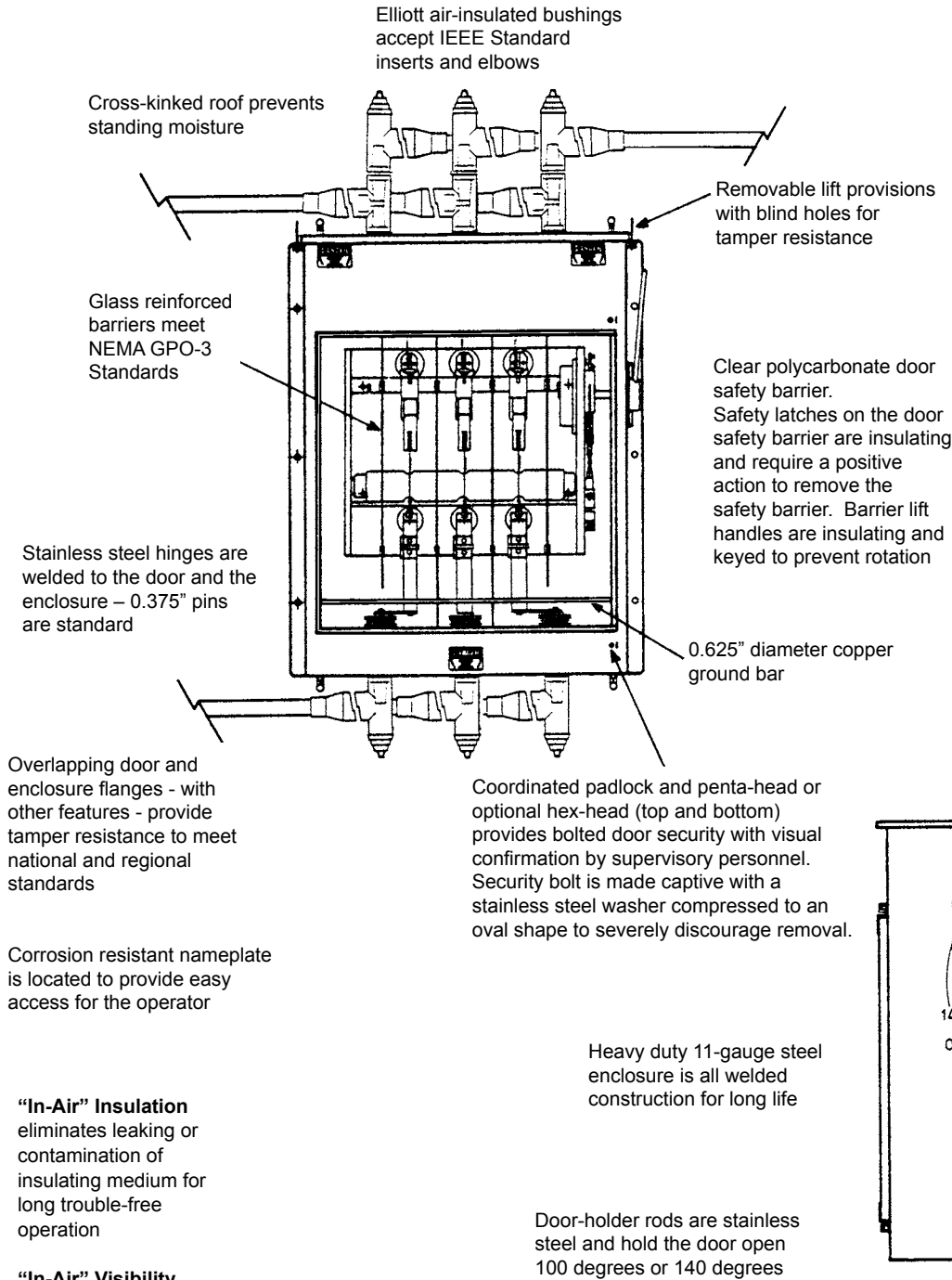

**Tamper-Resistant Enclosure** meets National and Regional Enclosure Integrity Standards and virtually eliminates the entrance of airborne contamination to reduce maintenance

**Superlife Finish** Includes phosphatizing, zinc rich epoxy primer and Pad-Mount Green (Munsell 7GY 3.29/1.5) polyurethane top coat - over 5 mils dry  
Optional Paint: Grey (Munsell 5BG 7.0/0.4)

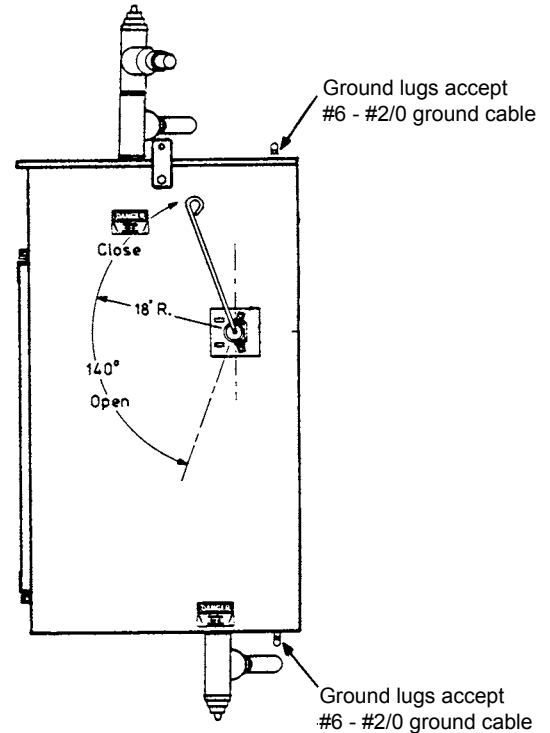

- ENCLOSURE OPTIONS:**
- 1) 0.125" #5052H32 Aluminum
  - 2) 12-gauge #304L Stainless Steel

# 25-kV Wall-Mount Switchgear 600 Amp S&C Mini-Rupter® Switch

Three Phase – Indoor/Outdoor

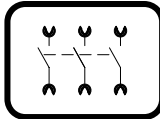

### Three Phase – Two Ways Per Phase

600 Amp 25 kV S&C #255243-S5 Mini-Rupter® Switch  
15.2/26.3 kV Grounded Wye Max Design  
125 kV BIL

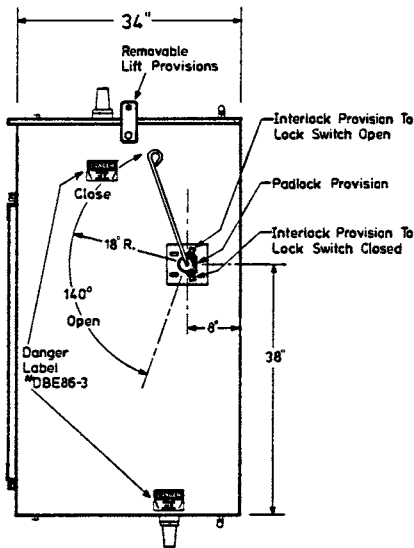

**Side View**

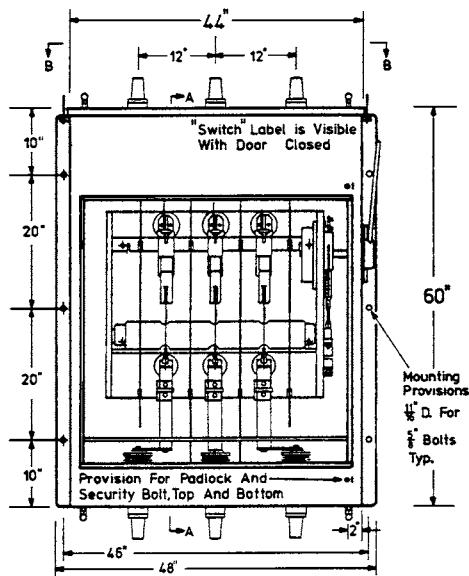

**Front View**  
Door & Door Safety  
Barrier Removed

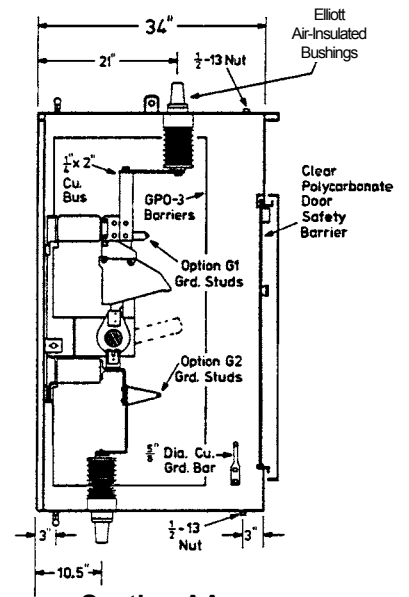

**Section AA**

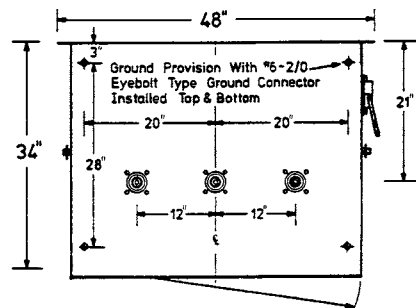

**Section BB**

600 Amp 25 kV S&C #255243-G3-S5 Mini-Rupter® Switch with non-removable handle located on right side, padlockable handle in "Open" or "Close" position, provisions for key interlock are standard

- 11-gauge Steel Enclosure
- Stainless Steel Hinges
- Provisions for padlock and stainless steel penta (or hex) bolt
- Clear polycarbonate door safety barrier standard
- 8" Min. Strike Distance to Ground
- 10" Min. Strike Distance Phase to Phase

- Standard Paint: "Pad-Mount Green"  
Munsell #7GY3.29/1.5
- Optional Paint: "Grey"  
Munsell #5BG7.0/0.4
- Option G1: Ground studs at main contact of switch
- Option G2: Ground studs at hinge end of switch
- Option K: Key interlock

Catalog Number	Bushings	Operating Handle
<b>EWMRG-25-311S-E2TB-RHMR</b>	200 Amp Bushing Wells Top and Bottom	Right Side (Shown Above)
<b>EWMRG-25-311S-E2TB-LHMR</b>	200 Amp Bushing Wells Top and Bottom	Left Side (Opposite Hand)
<b>EWMRG-25-311S-E6T/E2B-RHMR</b>	600 Amp Bushings - Top 200 Amp Bushing Wells - Bottom	Right Side (Shown Above)
<b>EWMRG-25-311S-E6T/E2B-LHMR</b>	600 Amp Bushings - Top 200 Amp Bushing Wells - Bottom	Left Side (Opposite Hand)
<b>EWMRG-25-311S-E6TB-RHMR</b>	600 Amp Bushings Top and Bottom	Right Side (Shown Above)
<b>EWMRG-25-311S-E6TB-LHMR</b>	600 Amp Bushings Top and Bottom	Left Side (Opposite Hand)

# 25-kV Wall-Mount Switchgear 600 Amp S&C Mini-Rupter® Switch

Three Phase – Indoor/Outdoor

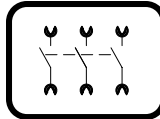

### Three Phase – Two Ways Per Phase

600 Amp 25 kV S&C #255243-S5 Mini-Rupter® Switch  
15.2/26.3 kV Grounded Wye Max Design  
125 kV BIL

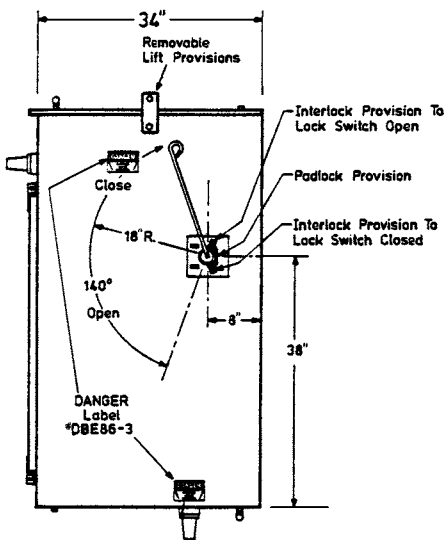

**Side View**

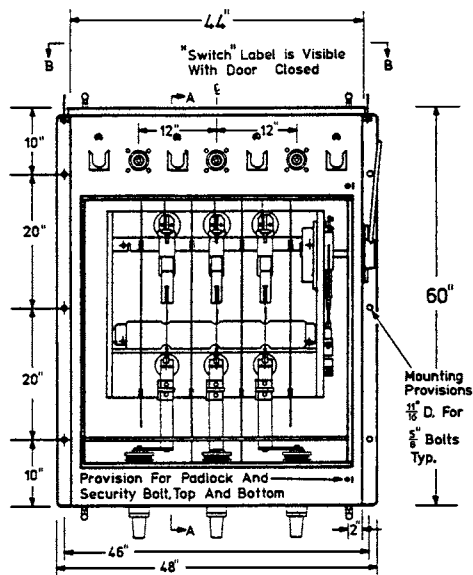

**Front View**

Door & Door Safety  
Barrier Removed

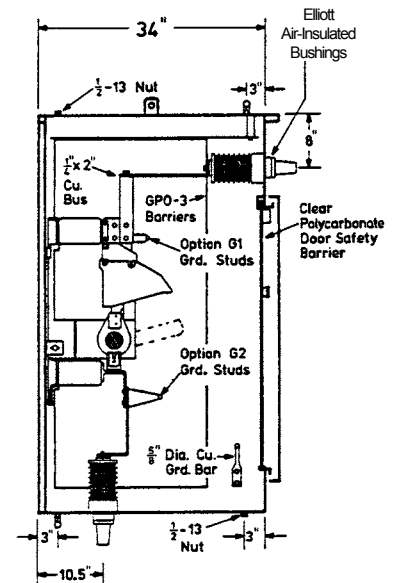

**Section AA**

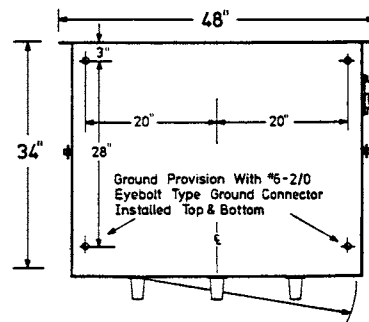

**Section BB**

600 Amp 25 kV S&C #255243-G3-S5 Mini-Rupter® Switch with non-removable handle located on right side, padlockable handle in "Open" or "Close" position, provisions for key interlock are standard

- 11-gauge Steel Enclosure
- Stainless Steel Hinges
- Provisions for padlock and stainless steel penta (or hex) bolt
- Clear polycarbonate door safety barrier standard
- 8" Min. Strike Distance to Ground
- 10" Min. Strike Distance Phase to Phase

- Standard Paint: "Pad-Mount Green"  
Munsell #7GY3.29/1.5
- Optional Paint: "Grey"  
Munsell #5BG7.0/0.4
- Option G1: Ground studs at main contact of switch
- Option G2: Ground studs at hinge end of switch
- Option K: Key interlock

Catalog Number	Bushings	Operating Handle
<b>EWMRG-25-311S-E2FB-RHMR</b>	200 Amp Bushing Wells Front and Bottom	Right Side (Shown Above)
<b>EWMRG-25-311S-E2FB-LHMR</b>	200 Amp Bushing Wells Front and Bottom	Left Side (Opposite Hand)
<b>EWMRG-25-311S-E6F/E2B-RHMR</b>	600 Amp Bushings - Front 200 Amp Bushing Wells - Bottom	Right Side (Shown Above)
<b>EWMRG-25-311S-E6F/E2B-LHMR</b>	600 Amp Bushings - Front 200 Amp Bushing Wells - Bottom	Left Side (Opposite Hand)
<b>EWMRG-25-311S-E6FB-RHMR</b>	600 Amp Bushings Front and Bottom	Right Side (Shown Above)
<b>EWMRG-25-311S-E6FB-LHMR</b>	600 Amp Bushings Front and Bottom	Left Side (Opposite Hand)

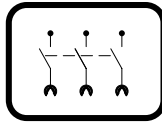

**Three Phase – Two Ways Per Phase**

600 Amp 25 kV S&C #255243-S5 Mini-Rupter® Switch  
15.2/26.3 kV Grounded Wye Max Design  
125 kV BIL

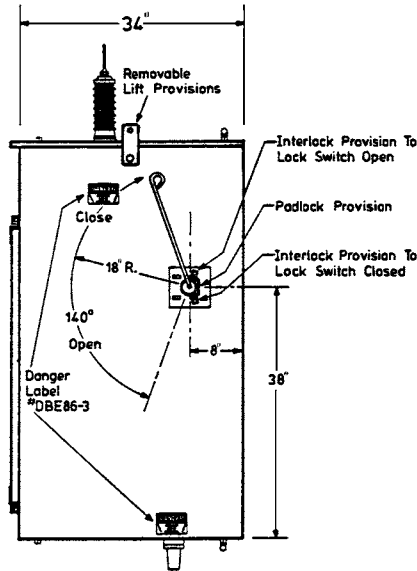

**Side View**

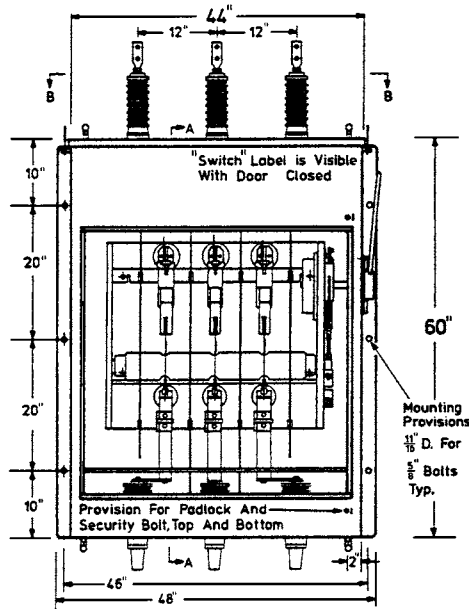

**Front View**

Door & Door Safety  
Barrier Removed

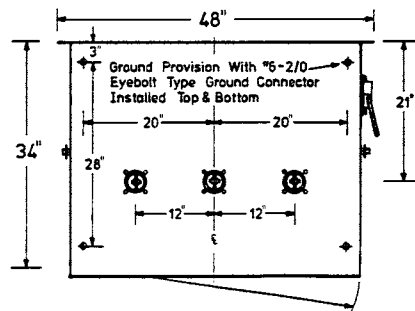

**Section BB**

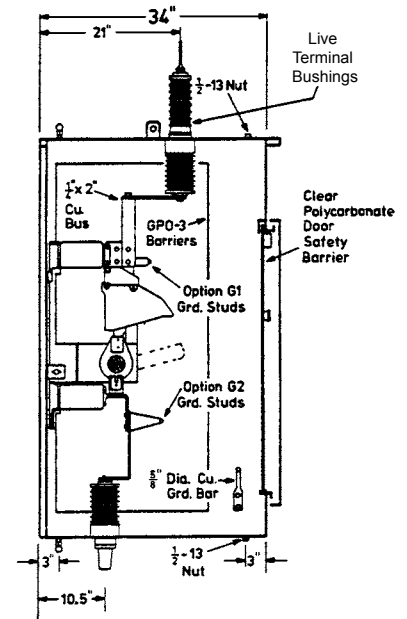

**Section AA**

600 Amp 25 kV S&C #255243-G3-S5 Mini-Rupter® Switch with non-removable handle located on right side, padlockable handle in "Open" or "Close" position, provisions for key interlock are standard

11-gauge Steel Enclosure  
Stainless Steel Hinges  
Provisions for padlock and stainless steel penta (or hex) bolt  
Clear polycarbonate door safety barrier standard  
8" Min. Strike Distance to Ground  
10" Min. Strike Distance Phase to Phase

Standard Paint: "Pad-Mount Green"  
Munsell #7GY3.29/1.5  
Optional Paint: "Grey"  
Munsell #5BG7.0/0.4  
Option G1: Ground studs at main contact of switch  
Option G2: Ground studs at hinge end of switch  
Option K: Key interlock

Catalog Number	Bushings	Operating Handle
<b>EWMRG-25-311S-EL6T/E2B-RHMR</b>	600 Amp Live Terminal Bushings - Top 200 Amp Bushing Wells - Bottom	Right Side (Shown Above)
<b>EWMRG-25-311S-EL6T/E2B-LHMR</b>	600 Amp Live Terminal Bushings - Top 200 Amp Bushing Wells - Bottom	Left Side (Opposite Hand)
<b>EWMRG-25-311S-EL6T/E6B-RHMR</b>	600 Amp Live Terminal Bushings - Top 600 Amp Bushings - Bottom	Right Side (Shown Above)
<b>EWMRG-25-311S-EL6T/E6B-LHMR</b>	600 Amp Live Terminal Bushings - Top 600 Amp Bushings - Bottom	Left Side (Opposite Hand)

**Elliott Floor Support Frame for Wall Mount Enclosure**  
Provides Additional Support When Wall Structure  
Is Inadequate or Questionable

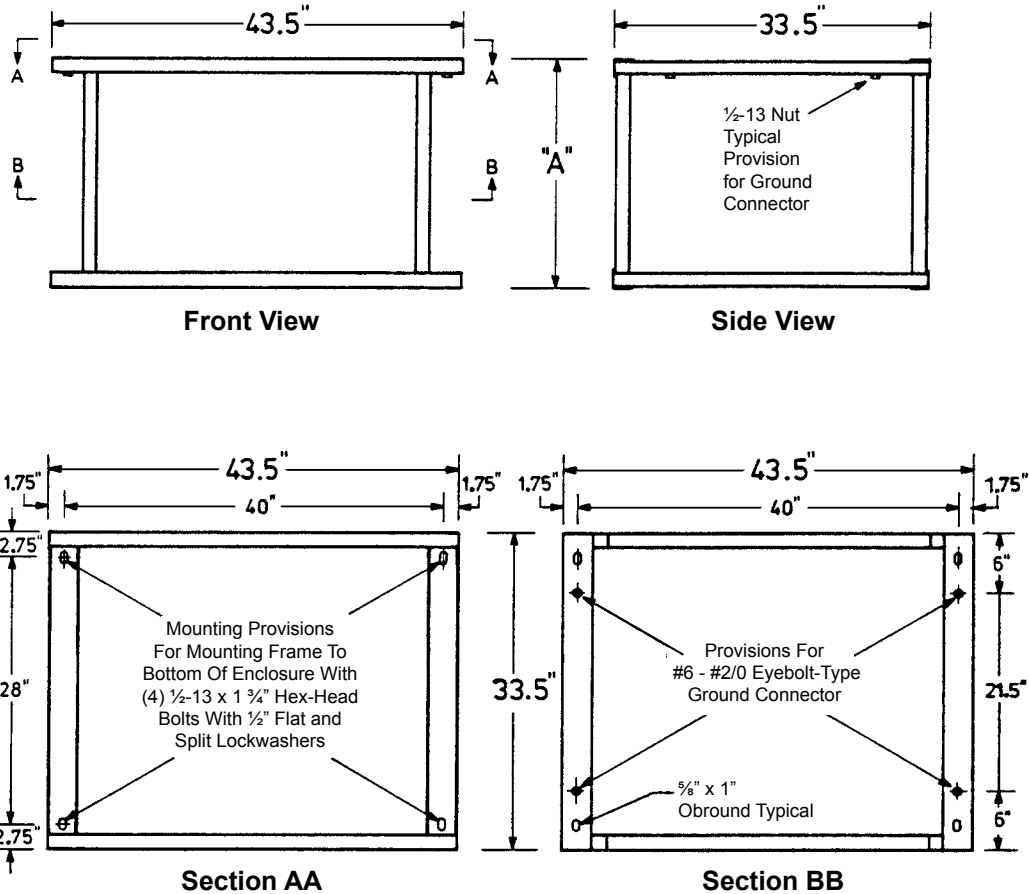

11-gauge Steel  
Standard Paint: "Pad-Mount Green"  
Munsell #7GY3.29/1.5  
Optional Paint: "Grey"  
Munsell #5BG7.0/0.4

Catalog Number	Dimension "A"
<b>EFSF-18-43.5-33.5</b>	<b>18"</b>
<b>EFSF-24-43.5-33.5</b>	<b>24"</b>
<b>EFSF-30-43.5-33.5</b>	<b>30"</b>
<b>EFSF-36-43.5-33.5</b>	<b>36"</b>
<b>EFSF-42-43.5-33.5</b>	<b>42"</b>



# 25-kV Wall-Mount Switchgear 600 Amp S&C Mini-Rupter® Switch

Three Phase – Indoor/Outdoor

Bulletin  
**550-226**  
Page 6 2007

## Typical Specification - Page 1 of 3

### General

The switchgear shall be 25 kV class, 125 kV BIL, 600 ampere continuous current, suitable for use on 15.2/26.3 kV grounded wye max design systems. The enclosure shall be designed for wall mounting and shall include provisions to accept a floor support frame that may be specified when a wall structure is questionable or inadequate to support the switchgear. The switchgear shall be constructed for connection to the utility system with noninsulated two-hole NEMA-standard connectors and/or separable insulated connectors as described in IEEE Standard 386—latest revision (separable insulated connectors [and loadbreak inserts when required] shall be supplied by the user). The switchgear shall be designed for and contain a three-pole, group-operated, interrupter switch that includes an external nonremovable side-mounted operating handle. The operating handle shall be padlockable in the open or the closed position and shall include provisions for key interlocks. A door safety barrier shall be provided inside the door on the switch compartment as recommended in IEEE Standard C2 (National Electrical Safety Code) Rule 381G. Tamper resistance shall meet the Enclosure Security requirements of IEEE Standard C57.12.28 (Pad-Mounted Equipment—Enclosure Integrity). Together, the tamper resistance and the door safety barrier shall resist unauthorized entry, protect authorized and unauthorized persons, and provide positive safety features when installed in areas accessible to the general public. The switchgear shall be constructed for indoor/outdoor installation in areas subject to precipitation and in areas with windblown contamination. The equipment shall be “air-insulated” and completely assembled prior to shipment.

### Enclosure Construction

The enclosure shall be tamper-resistant, all-welded construction utilizing 11-gauge minimum sheet steel. Single and double 90 degree bends shall be used as necessary to assure strength and rigidity. The enclosure top shall be kinked to provide watershed and rigidity. The switch compartment access door shall be furnished with a stainless steel door holder that will latch the door open 100 degrees and 140 degrees and resist accidental closing. The door shall be provided with provisions for padlocking and a recessed penta-head (or hex-head) security bolt to prevent unauthorized entry (coordinated to prevent installation of the padlock until the security bolt is tightened *when closing the door(s)* and to prevent a wrench from operating the security bolt until the padlock is removed *when opening the door(s)*). The security bolt shall be made captive with a stainless steel washer compressed to an oval shape to severely discourage removal. Hinges shall be stainless steel (with stainless steel pins not less than 0.3125-inch diameter) and shall

be welded to both the enclosure and the door to maintain door alignment for the life of the equipment. The enclosure shall be nonventilated to minimize the entrance of airborne contamination, insects, rodents or reptiles. The protective finish shall include necessary grinding, 5-stage cleaning and phosphatizing, two-component rust-inhibiting zinc rich epoxy primer and a Pad-Mount Green two-component polyurethane top coat finish—Munsell color 7GY 3.29/1.5 (or Optional Grey—Munsell color 5BG 7.0/0.4). The primer and top coat shall be electronically monitored during application to insure proper ratio and mixing of each component. Total average thickness of paint (after curing) shall be not less than 5 mils. The protective coating shall meet the Enclosure Coating System requirements of IEEE Standard C57.12.28 (Pad-Mounted Equipment—Enclosure Integrity). Removable lift provisions, adequate to withstand handling with normal utility equipment, shall be provided on the outside of the enclosure. Threaded openings for lift provision bolts shall be blind holes to prevent the entrance of wire or other foreign objects into the enclosure when lift provisions are removed.

Four threaded openings for attachment of a floor support frame (to provide additional support when a wall structure is questionable or inadequate) shall be provided on the bottom of the enclosure. The threaded openings shall be blind holes and shall be unpainted internally to provide a ground for the floor support frame that may be installed. When specified, an 18-inch (alternate 24-inch, 30-inch, 36-inch or 42-inch) high floor support frame shall be supplied bolted in place with stainless-steel hardware. The floor support frame shall be all-welded construction utilizing 11-gauge minimum sheet steel formed to assure strength and rigidity. The two ground lugs specified for the bottom of the enclosure shall be installed on the floor support frame not more than 6 inches from the original location. The protective coating of the floor support frame shall meet or exceed the coating requirements specified above for the enclosure.

### Bushings and Terminals

**Alternate 1:** Bushings shall be 200 ampere Elliott #1101-225B, 25 kV class (15.2 kV to ground) Air-Insulated Bushing Wells, 125 kV BIL, per IEEE Standard 386 Fig. 3 (200 A Bushing Well Interface, 8.3 kV, 15.2 kV and 21.1 kV) *for use with either 8.3/14.4 kV or 15.2/26.3 kV separable insulated connectors* (Elastimold®, Cooper Power Systems [RTE®] or other approved equal). The bushing wells shall be pressure-molded cycloaliphatic epoxy with a 0.75-inch diameter copper conductor on the “air-insulated” side that is drilled and tapped 0.375-inch – 16UNC x 1-inch deep to provide direct connection of the bus and/or live parts. Leakage distance from the apparatus connection end of the bushing well to ground shall be not less than 30 inches to assure trouble-free operation in



# 25-kV Wall-Mount Switchgear 600 Amp S&C Mini-Rupter® Switch

Three Phase – Indoor/Outdoor

Bulletin  
**550-226**  
Page 7 2007

## Typical Specification - Page 2 of 3

a wet and/or contaminated environment. Integral shielding shall be provided to eliminate partial discharge caused by off-center mounting and mounting holes that may have sharp edges or burrs. Bushing wells shall mount in a 3.125-inch diameter opening and bolt in place to allow field replacement with standard tools. The bushing mounting bolts shall be self-locking stainless steel serrated-flange hex-head bolts that cut through the enclosure protective finish to ground the integral shielding of each bushing. The head of one or more of the mounting bolts for each bushing shall include a 0.156-inch diameter hole to provide a connection to ground for the loadbreak insert shielding ground wire as recommended by separable insulated connector manufacturers. To assure adequate strength for apparatus support, the bushing well shall withstand a minimum cantilever loading of 600 pounds for five minutes without damage. The bushing well interface shall be free of all voids, holes and heat sinks to assure proper mating with separable insulated connectors. Each bushing well shall be tested in free air, mounted in a grounded steel plate not less than 10 inches x 10 inches, and with a bushing well plug (RTE® #IBWP225 or equal) installed in the well interface to accurately simulate operating conditions (*gas or liquid dielectric in the interface shall not be acceptable for this test*). Each bushing well shall meet the requirements for 25 kV devices in accordance with IEEE Standard 386 (latest revision), including 100 percent production testing.

**Alternate 2:** Bushings shall be 600 ampere Elliott #1201-625B2, 25 kV class (15.2 kV to ground) Air-Insulated Bushings, 125 kV BIL, per IEEE Standard 386 Fig. 10 (600 A Deadbreak Interface, 8.3 kV and 15.2 kV) *for use with either 8.3/14.4 kV or 15.2/26.3 kV separable insulated connectors* (Elastimold®, Cooper Power Systems [RTE®] or other approved equal). The bushings shall be pressure-molded cycloaliphatic epoxy with a 1.25-inch diameter tin-plated aluminum conductor on the “air-insulated” side that is drilled and tapped 0.625-inch – 11UNC x 1-inch deep to provide direct connection of the bus and/or live parts. Leakage distance from the apparatus connection end of the bushing to ground shall be not less than 30 inches to assure trouble-free operation in a wet and/or contaminated environment. Integral shielding shall be provided to eliminate partial discharge caused by off-center mounting and mounting holes that may have sharp edges or burrs. Bushings shall mount in a 3.125-inch diameter opening and bolt in place to allow field replacement with standard tools. The bushing mounting bolts shall be self-locking stainless steel serrated-flange hex-head bolts that cut through the enclosure protective finish to ground the integral shielding of each bushing. To assure adequate strength for apparatus support, the bushing shall withstand a minimum cantilever loading of 600 pounds for five minutes without damage. The bushing interface shall be free of all voids,

holes and heat sinks to assure proper mating with separable insulated connectors. Each bushing shall be tested in free air, mounted in a grounded steel plate not less than 10 inches x 10 inches, and with an insulated protective cap (RTE® #DPC625 or equal) installed on the interface to accurately simulate operating conditions (*gas or liquid dielectric on the interface shall not be acceptable for this test*). Each bushing shall meet the requirements for 25 kV devices in accordance with the test values of IEEE Standard 386 (latest revision), including 100 percent production testing.

**Alternate 3:** Bushings shall be 600 ampere Elliott #1351-625TB, 25 kV class (15.2 kV to ground) Air-Insulated Live-Terminal Thru-Bushings, 125 kV BIL, *for use on either 8.3/14.4 kV or 15.2/26.3 kV systems*. The bushings shall be pressure-molded cycloaliphatic epoxy with a 1.25-inch diameter tin-plated aluminum conductor that is drilled and tapped 0.625-inch – 11UNC x 1-inch deep on both ends to provide for connection of the bus and/or live parts. The end of the bushing that is external to the enclosure shall be provided with a copper two-hole NEMA standard terminal for connection to the utility electrical system. Integral shielding shall be provided to eliminate partial discharge caused by off-center mounting and mounting holes that may have sharp edges or burrs. Bushings shall mount in a 3.125-inch diameter opening and bolt in place to allow field replacement with standard tools. The bushing mounting bolts shall be self-locking stainless steel serrated-flange hex-head bolts that cut through the enclosure protective finish to ground the integral shielding of each bushing. To assure adequate strength for apparatus support, the bushing well shall withstand a minimum cantilever loading of 500 pounds for five minutes without damage. Each bushing shall be tested in free air, mounted in a grounded steel plate not less than 10 inches x 10 inches and shall meet the requirements for 25 kV devices in accordance with the test values of IEEE Standard 386 (latest revision), including 100 percent production testing.

### Interrupter Switch

The three-pole, group-operated interrupter switch shall be S&C #255243-S5, 25 kV class, 125 kV BIL, 600 amp Mini-Rupter® that includes an external nonremovable side-mounted (or front-mounted) operating handle. The interrupter switch shall include a quick-make quick-break mechanism that will quickly and positively open and close the switch blades independent of the switch-operating hub speed. An arc-chute shall be provided for each switched pole and circuit interruption shall take place within the arc-chute. Any exhaust from the arc-chute shall be vented in a controlled manner. The interrupter switch and other electrical components shall be “air-insulated” and positioned to allow visual inspection of the switch position and all



# 25-kV Wall-Mount Switchgear 600 Amp S&C Mini-Rupter® Switch

Three Phase – Indoor/Outdoor

Bulletin  
**550-226**  
Page 8 2007

## Typical Specification - Page 3 of 3

internal connections and components *without removing the clear-polycarbonate door safety barrier*, de-energizing or removing the equipment from service. The operating handle shall be padlockable in the open or the close position. *When Option G1 is specified*, ground studs shall be provided for each terminal at the main contact end of the interrupter switch. *When Option G2 is specified*, ground studs shall be provided for each terminal at the hinge end of the interrupter switch. *When Option K is specified*, key interlocks shall be provided that require operations in a given sequence.

### Bus

Bus shall be copper with all burrs and sharp corners removed prior to installation. Positive pressure shall be assured by use of stainless steel fasteners and lock washers at all connection points. All connections shall provide direct contact of current-carrying parts and shall not depend on current transfer through fastener thread-to-thread contact. Electrical components shall be “air-insulated” and positioned to allow visual inspection of all internal connections and components *without removing the clear-polycarbonate door safety barrier*, de-energizing or removing the equipment from service.

### Barriers

Phase and ground barriers shall be provided to assure correct phase-to-phase and phase-to-ground clearances for correct operation at rated voltage. These barriers shall be glass-reinforced polyester (NEMA GPO-3 class material) not less than 0.1875-inch thick.

A removable insulating barrier with a “DANGER – Keep Out! – Hazardous voltage” sign, Elliott #7203-D2003-309, shall be located inside the door(s) on the switch compartment as recommended in Rule 381G of IEEE Standard C2 (National Electrical Safety Code). This door safety barrier shall be constructed of 0.25-inch clear polycarbonate (Lexan or equal) and *shall completely close the door opening* and be provided with a nonconductive safety latch requiring a positive action to remove the barrier. Handles and other hardware extending through this door safety barrier shall be nonconductive material. Handles shall be keyed to prevent rotation for secure handling. *Complete visual inspection of the internal components shall be possible without removing the door safety barrier.*

### Grounding Provisions

Four high-conductivity bronze eyebolt-type ground lugs, which accept #6 through #2/0 copper conductor, shall

be installed on the enclosure (two on the exterior of the top and two on the exterior of the bottom). One 0.625-inch diameter copper grounding bar that bolts to both walls inside the enclosure shall be provided near the bottom of the door opening in a position easily accessible for attachment of grounding clamps. When grounding clamps are installed it shall be possible to close and lock the door.

### Accessory Equipment

Stainless steel parking stands shall be provided in the quantity required to allow use of feed-thru bushings, parking bushings and grounding bushings. The parking stands shall be welded in place, in a position to allow the use of hot-line tools for installation of feed-thru bushings, etc. The parking stands shall be *unpainted* (except welds shall be painted) *to provide a ground* for feed-thru bushings and other devices that may be placed into the parking stands. *Keyed retainers* shall be welded above each parking stand *to prevent slipping or accidental removal* of portable devices such as feed-thru bushings, etc.

An anodized aluminum nameplate shall be installed inside the compartment door. It shall be located at the top corner farthest from the enclosure when the door is open. The nameplate will provide Type of Equipment, Model Number, Amps Continuous, kV Maximum, BIL, Serial Number, Date Manufactured and Weight of Equipment.

The enclosure shall be labeled in near proximity of the locking provisions with a pressure-sensitive vinyl label using letters not less than 0.375-inch nor more than 0.625-inch high. The label shall indicate the type of equipment behind the access (switch, fuses, bus, etc.).

### Packaging

Each switchgear shall be bolted to a solid-top wood pallet to prevent hidden damage. The equipment shall be wrapped with 0.125-inch thick polyethylene foam or other suitable material to minimize damage to the finish during shipment.

### Drawings

When specified, drawings shall be furnished for each switchgear that include:

- 1) enclosure dimensions and location of components.
- 2) proposed labels and location of labels.