

**ENCLOSURE OPTIONS:**

- 1) 0.125" #5052H32 Aluminum
- 2) 12-gauge #304L Stainless Steel

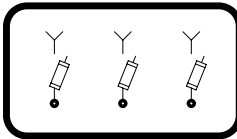

**Three Phase – Two Ways Per Phase**

200 Amp Elliott Air-Insulated Bushing Wells  
15.2/26.3 kV Grounded Wye Max Design  
125 kV BIL

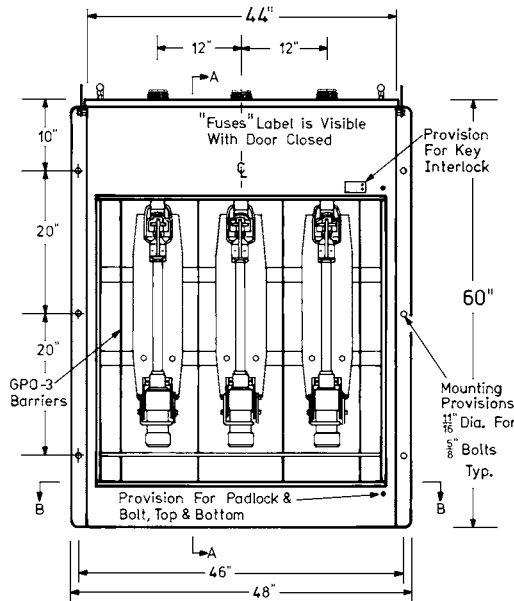
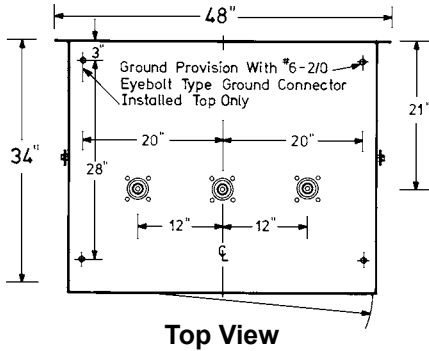

**Front View**  
Door & Door Safety  
Barrier Removed

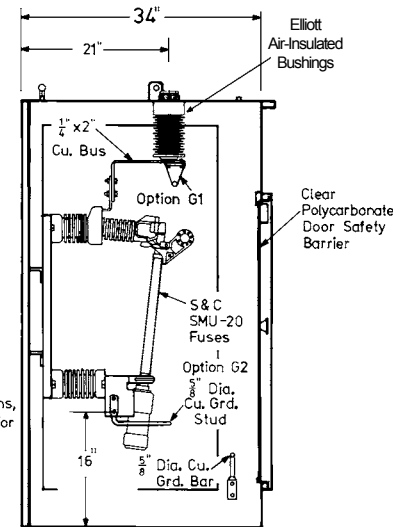

**Section AA**

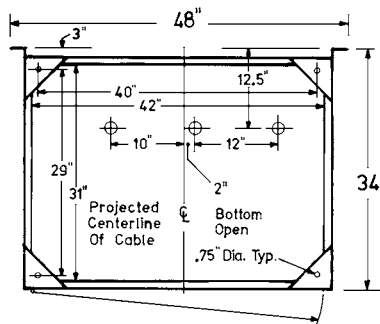

**Section BB**

11-gauge Steel Enclosure  
Stainless Steel Hinges  
Provisions for padlock and stainless steel penta (or hex) bolt  
Clear polycarbonate door safety barrier standard  
8" Min. Strike Distance to Ground  
10" Min. Strike Distance Phase to Phase

Standard Paint: "Pad-Mount Green"  
Munsell #7GY3.29/1.5  
Optional Paint: "Grey"  
Munsell #5BG7.0/0.4  
Option G1: Ground studs at main contact of fuse mounting  
Option G2: Ground studs at hinge end of fuse mounting  
Option K: Key interlock

Catalog Number	Fuse Mounting	Fuse End Fittings/Holder	Fuse Unit/Refill
<b>EWMR-25-311S-E2T/LT-SML20</b>	SML-20 with Uni-Rupter®	SM-20 Cat. #3097	SMU-20 200K or 200E Max
<b>EWMR-25-311S-E2T/LT-SM20</b>	SM-20 without Uni-Rupter®	SM-20 Cat. #3097	SMU-20 200K or 200E Max
<b>EWMR-25-311S-E2T/LT-SML4</b>	SML-4Z with Uni-Rupter®	SML-4Z Cat. #92357	SM-4 200E Max
<b>EWMR-25-311S-E2T/LT-SMX4</b>	SMX-4 without Uni-Rupter®	SML-4Z Cat. #92357	SM-4 200E Max

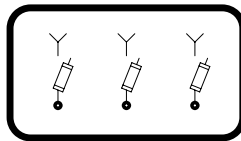

**Three Phase – Two Ways Per Phase**

200 Amp Elliott Air-Insulated Bushing Wells  
 15.2/26.3 kV Grounded Wye Max Design  
 125 kV BIL

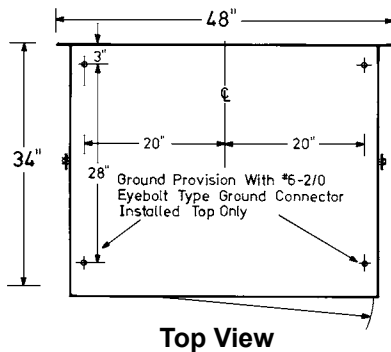

**Top View**

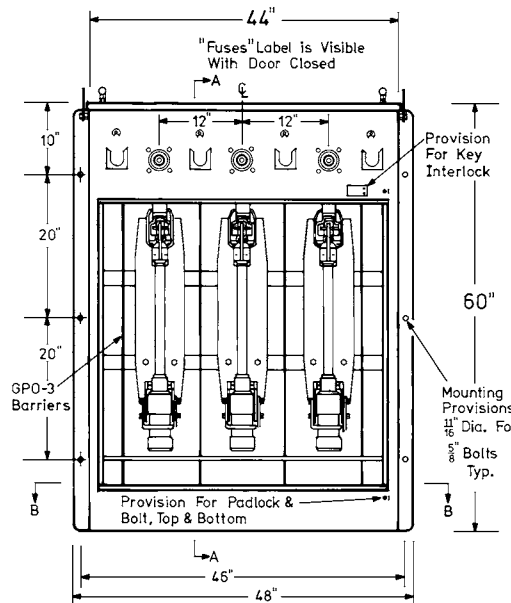

**Front View**  
 Door & Door Safety  
 Barrier Removed

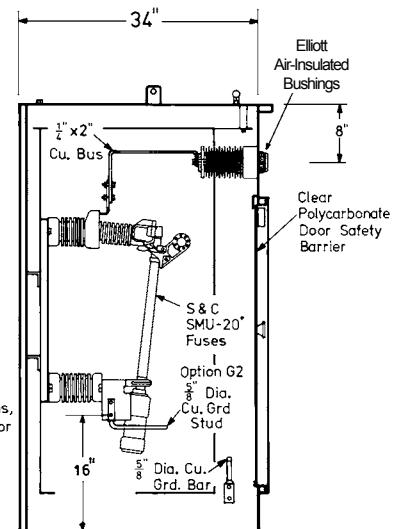

**Section AA**

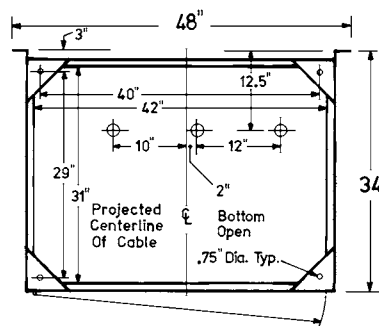

**Section BB**

11-gauge Steel Enclosure  
 Stainless Steel Hinges  
 Provisions for padlock and stainless steel penta (or hex) bolt  
 Clear polycarbonate door safety barrier standard  
 8" Min. Strike Distance to Ground  
 10" Min. Strike Distance Phase to Phase

Standard Paint: "Pad-Mount Green"  
 Munsell #7GY3.29/1.5  
 Optional Paint: "Grey"  
 Munsell #5BG7.0/0.4  
 Option G1: Ground studs at main contact of fuse mounting  
 Option G2: Ground studs at hinge end of fuse mounting  
 Option K: Key interlock

Catalog Number	Fuse Mounting	Fuse End Fittings/Holder	Fuse Unit/Refill
<b>EWMR-25-311S-E2F/LT-SML20</b>	SML-20 with Uni-Rupter®	SM-20 Cat. #3097	SMU-20 200K or 200E Max
<b>EWMR-25-311S-E2F/LT-SM20</b>	SM-20 without Uni-Rupter®	SM-20 Cat. #3097	SMU-20 200K or 200E Max
<b>EWMR-25-311S-E2F/LT-SML4</b>	SML-4Z with Uni-Rupter®	SML-4Z Cat. #92357	SM-4 200E Max
<b>EWMR-25-311S-E2F/LT-SMX4</b>	SMX-4 without Uni-Rupter®	SML-4Z Cat. #92357	SM-4 200E Max

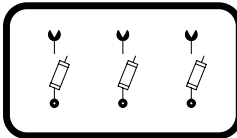

**Three Phase – Two Ways Per Phase**  
200 Amp Elliott Air-Insulated Bushing Wells  
15.2/26.3 kV Grounded Wye Max Design  
125 kV BIL

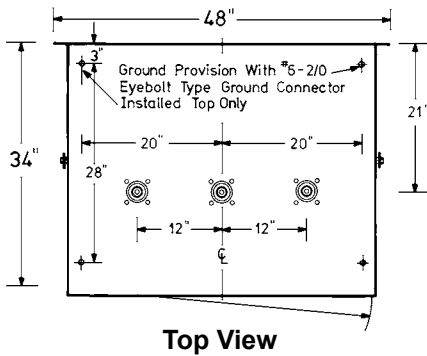

**Top View**

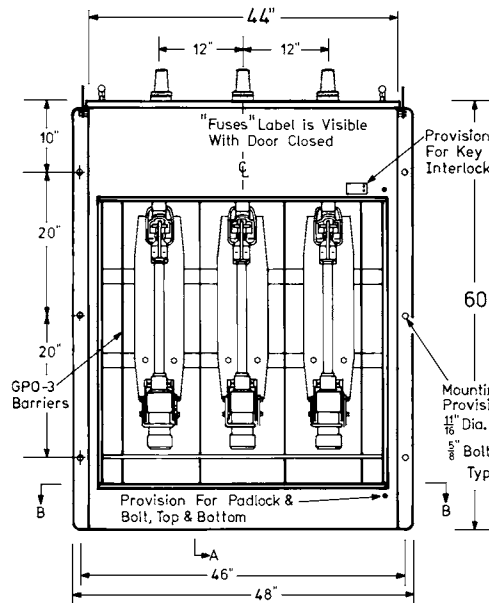

**Front View**  
Door & Door Safety  
Barrier Removed

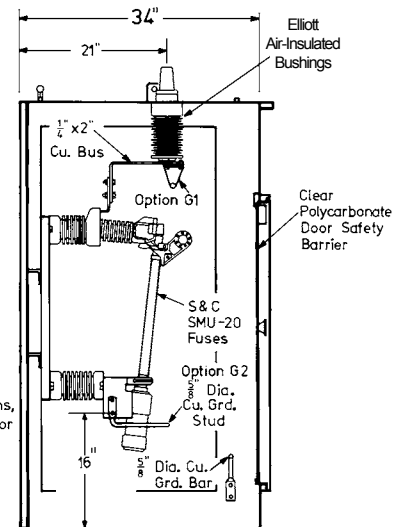

**Section AA**

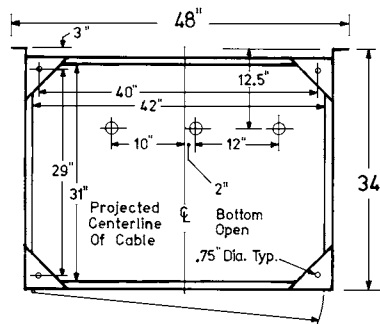

**Section BB**

11-gauge Steel Enclosure  
Stainless Steel Hinges  
Provisions for padlock and stainless steel penta (or hex) bolt  
Clear polycarbonate door safety barrier standard  
8" Min. Strike Distance to Ground  
10" Min. Strike Distance Phase to Phase

Standard Paint: "Pad-Mount Green"  
Munsell #7GY3.29/1.5  
Optional Paint: "Grey"  
Munsell #5BG7.0/0.4  
Option G1: Ground studs at main contact of fuse mounting  
Option G2: Ground studs at hinge end of fuse mounting  
Option K: Key interlock

Catalog Number	Fuse Mounting	Fuse End Fittings/Holder	Fuse Unit/Refill
<b>EWMR-25-311S-E6T/LT-SML20</b>	SML-20 with Uni-Rupter®	SM-20 Cat. #3097	SMU-20 200K or 200E Max
<b>EWMR-25-311S-E6T/LT-SM20</b>	SM-20 without Uni-Rupter®	SM-20 Cat. #3097	SMU-20 200K or 200E Max
<b>EWMR-25-311S-E6T/LT-SML4</b>	SML-4Z with Uni-Rupter®	SML-4Z Cat. #92357	SM-4 200E Max
<b>EWMR-25-311S-E6T/LT-SMX4</b>	SMX-4 without Uni-Rupter®	SML-4Z Cat. #92357	SM-4 200E Max

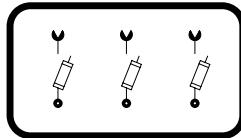

**Three Phase – Two Ways Per Phase**  
200 Amp Elliott Air-Insulated Bushing Wells  
15.2/26.3 kV Grounded Wye Max Design  
125 kV BIL

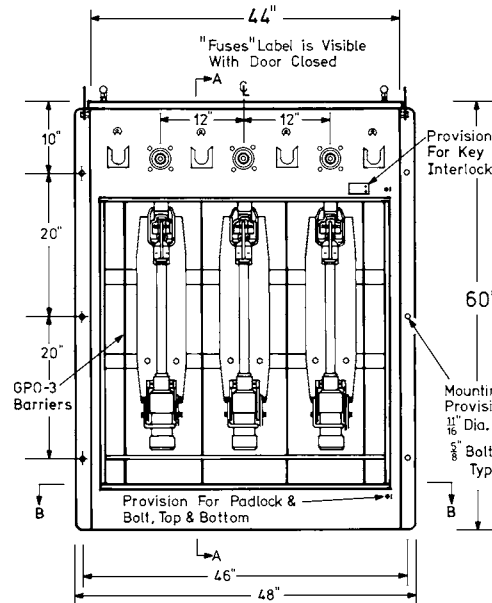
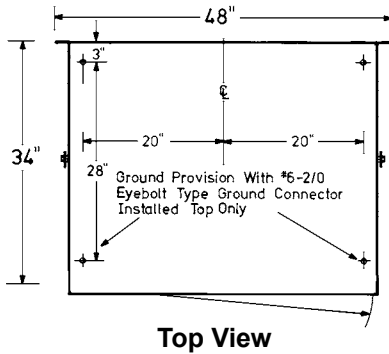

**Front View**  
Door & Door Safety  
Barrier Removed

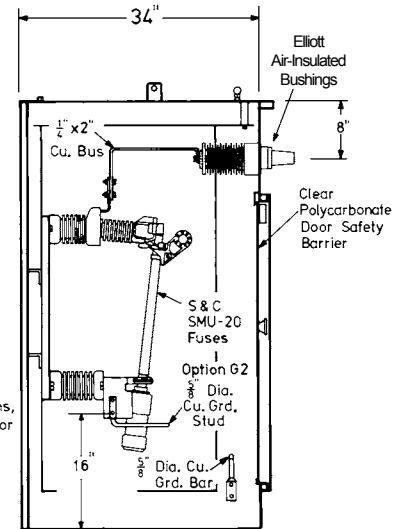

**Section AA**

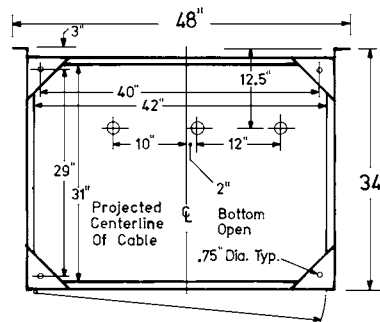

**Section BB**

11-gauge Steel Enclosure  
Stainless Steel Hinges  
Provisions for padlock and stainless steel penta (or hex) bolt  
Clear polycarbonate door safety barrier standard  
8" Min. Strike Distance to Ground  
10" Min. Strike Distance Phase to Phase

Standard Paint: "Pad-Mount Green"  
Munsell #7GY3.29/1.5  
Optional Paint: "Grey"  
Munsell #5BG7.0/0.4  
Option G1: Ground studs at main contact of fuse mounting  
Option G2: Ground studs at hinge end of fuse mounting  
Option K: Key interlock

Catalog Number	Fuse Mounting	Fuse End Fittings/Holder	Fuse Unit/Refill
<b>EWMR-25-311S-E6F/LT-SML20</b>	SML-20 with Uni-Rupter®	SM-20 Cat. #3097	SMU-20 200K or 200E Max
<b>EWMR-25-311S-E6F/LT-SM20</b>	SM-20 without Uni-Rupter®	SM-20 Cat. #3097	SMU-20 200K or 200E Max
<b>EWMR-25-311S-E6F/LT-SML4</b>	SML-4Z with Uni-Rupter®	SML-4Z Cat. #92357	SM-4 200E Max
<b>EWMR-25-311S-E6F/LT-SMX4</b>	SMX-4 without Uni-Rupter®	SML-4Z Cat. #92357	SM-4 200E Max

**Elliott Floor Support Sleeve with *Outside* Floor Mounting Flange  
For Wall/Base-Mount Enclosure**  
Provides support and encloses bottom entrance cables

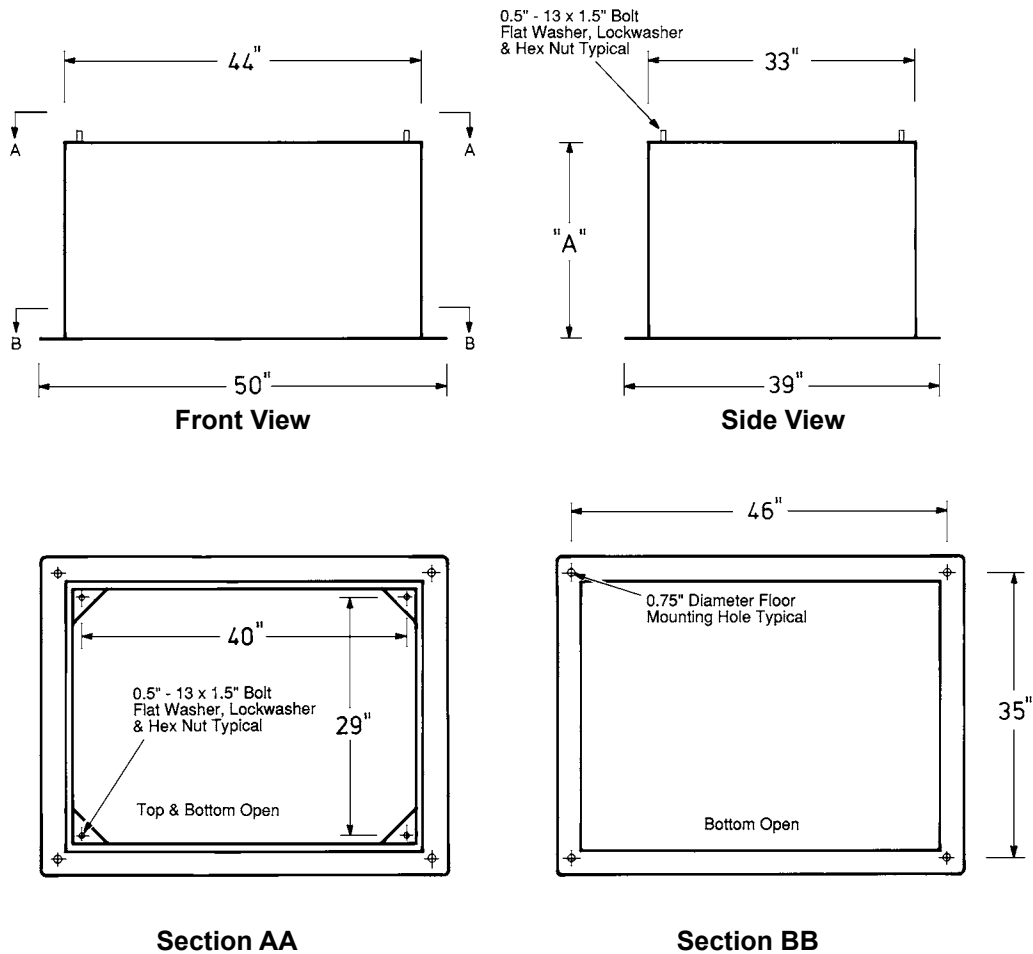

11-gauge Steel  
Standard Paint: "Pad-Mount Green"  
Munsell #7GY3.29/1.5  
Optional Paint: "Grey"  
Munsell #5BG7.0/0.4

Catalog Number	Dimension "A"	Wide	Deep
EFSSOF-18-44-33	18"	44"	33"
EFSSOF-24-44-33	24"	44"	33"
EFSSOF-30-44-33	30"	44"	33"
EFSSOF-36-44-33	36"	44"	33"



**25-kV Wall/Base-Mount Fuse-Gear  
200 Amp S&C SMU-20 and SM-4 Fuses**  
Three Phase – Indoor/Outdoor

Bulletin  
**550-214**  
Page 7 2007

**Elliott Floor Support Sleeve with *Inside* Floor Mounting Flange  
For Wall/Base-Mount Enclosure**  
Provides support and encloses bottom entrance cables

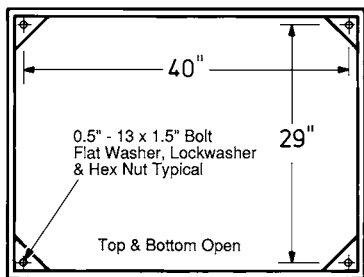
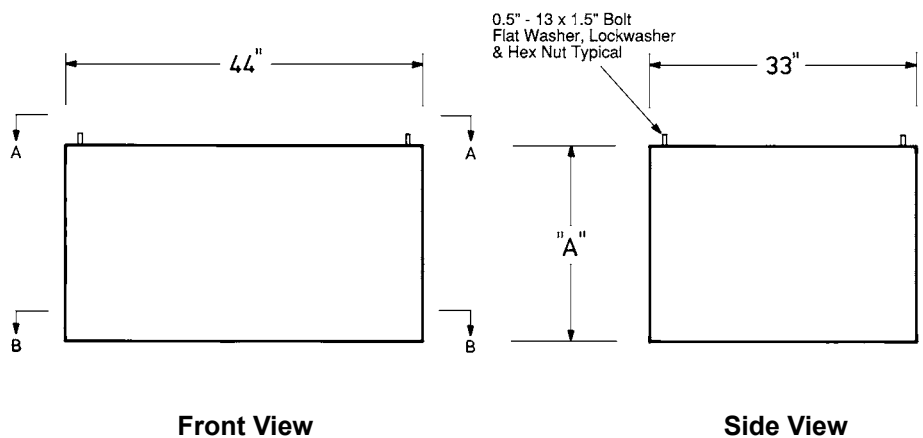

**Section AA**

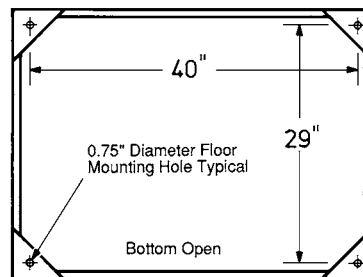

**Section BB**

11-gauge Steel  
Standard Paint: "Pad-Mount Green"  
Munsell #7GY3.29/1.5  
Optional Paint: "Grey"  
Munsell #5BG7.0/0.4

Catalog Number	Dimension "A"	Wide	Deep
EFSSIF-18-44-33	18"	44"	33"
EFSSIF-24-44-33	24"	44"	33"
EFSSIF-30-44-33	30"	44"	33"
EFSSIF-36-44-33	36"	44"	33"

ELASTIMOLD® is a registered trademark of Elastimold, A Unit of Thomas and Betts  
RTE® is a registered trademark of Cooper Industries, Inc.

Uni-Rupter® is a registered trademark of S&C Electric Company



# 25-kV Wall/Base-Mount Fuse-Gear 200 Amp S&C SMU-20 and SM-4 Fuses Three Phase – Indoor/Outdoor

Bulletin  
**550-214**  
Page 8 2007

## Bushing Wells and Bushings

The wall/base-mount fuse-gear shown in this bulletin are provided with Elliott 200 amp or 600 amp bushings which utilize the same mounting holes and mounting hardware. If circuit requirements change, 200 amp bushing wells may be replaced with 600 amp bushings (600 amp bushings may be replaced with 200 amp bushing wells also).

**NOTE:** The fuse-gear must be de-energized and grounded in accordance with your company's normal safety procedure before any modifications are made.

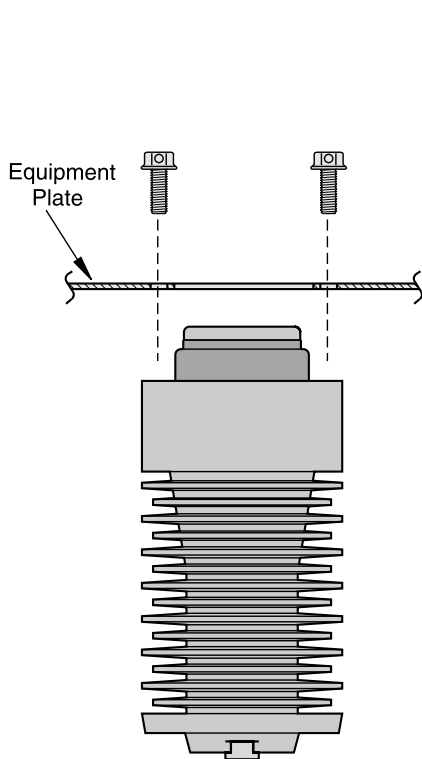

**Elliott Catalog #1101-225B**

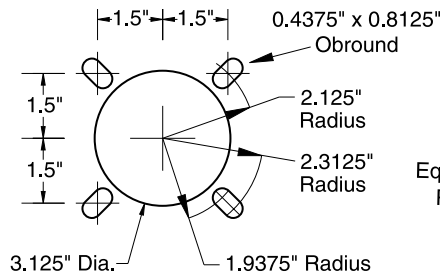

**Uni-Mount Mounting Holes  
accepts Elliott and S&C Bushings**

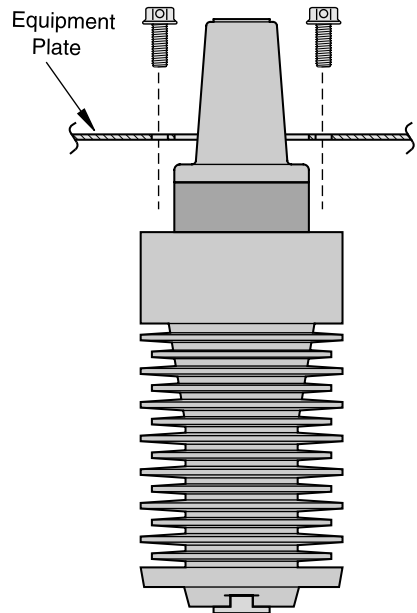

**Elliott Catalog #1201-625B2**

### Electrical Ratings

Voltage Class.....	25 kV
Phase-to-Ground Voltage.....	15.2 kV
BIL.....	125 kV
A.C. Withstand - 1 Min. Dry.....	40 kV
10 Sec. Dew.....	40 kV
D.C. Withstand - 15 Min. Dry.....	78 kV
Corona Extinction Level - Minimum.....	19 kV
Continuous Current.....	200 Amps
8 Hr. Overload.....	300 Amps
Momentary - RMS, Sym., 0.17 sec.....	10,000 Amps
RMS, Sym., 3 sec.....	3,500 Amps

### Electrical Ratings

Voltage Class.....	25 kV
Phase-to-Ground Voltage.....	15.2 kV
BIL.....	125 kV
A.C. Withstand - 1 Min. Dry.....	40 kV
10 Sec. Dew.....	40 kV
D.C. Withstand - 15 Min. Dry.....	78 kV
Corona Extinction Level - Minimum.....	19 kV
Continuous Current.....	600 Amps
8 Hr. Overload.....	900 Amps
Momentary - RMS, Sym., 0.17 sec.....	25,000 Amps
RMS, Sym., 3 sec.....	10,000 Amps

ELASTIMOLD® is a registered trademark of Elastimold, A Unit of Thomas and Betts  
RTE® is a registered trademark of Cooper Industries, Inc.

Uni-Rupter® is a registered trademark of S&C Electric Company

## Typical Specification - Page 1 of 3

### General

The fuse-gear shall be 25 kV class, 125 kV BIL, 600 ampere continuous current, suitable for use on 15.2/26.3 kV grounded wye max design systems. The enclosure shall be designed for wall/base mounting and shall include provisions to accept a floor support sleeve that may be specified to support the fuse-gear and to enclose the bottom entrance cables. The fuse-gear shall be constructed for connection to the utility system with noninsulated two-hole NEMA-standard connectors and/or separable insulated connectors as described in IEEE Standard 386—latest revision (separable insulated connectors [and loadbreak inserts when required] shall be supplied by the user). The fuse-gear shall be designed for and contain three fuse mountings as described below. A door safety barrier shall be provided inside the door on the fuse compartment as recommended in IEEE Standard C2 (National Electrical Safety Code) Rule 381G. Tamper resistance shall meet the Enclosure Security requirements of IEEE Standard C57.12.28 (Pad-Mounted Equipment—Enclosure Integrity). Together, the tamper resistance and the door safety barrier shall resist unauthorized entry, protect authorized and unauthorized persons, and provide positive safety features when installed in areas accessible to the general public. The fuse-gear shall be constructed for indoor/outdoor installation in areas subject to precipitation and in areas with windblown contamination. The equipment shall be “air-insulated” and completely assembled prior to shipment.

### Enclosure Construction

The enclosure shall be tamper-resistant, all-welded construction utilizing 11-gauge minimum sheet steel. Single and double 90 degree bends shall be used as necessary to assure strength and rigidity. The enclosure top shall be kinked to provide watershed and rigidity. The fuse compartment access door shall be furnished with a stainless steel door holder that will latch the door open 100 degrees and 140 degrees and resist accidental closing. The door shall be provided with provisions for padlocking and a recessed penta-head (or hex-head) security bolt to prevent unauthorized entry (coordinated to prevent installation of the padlock until the security bolt is tightened *when closing the door(s)* and to prevent a wrench from operating the security bolt until the padlock is removed *when opening the door(s)*). The security bolt shall be made captive with a stainless steel washer compressed to an oval shape to severely discourage removal. Hinges shall be stainless steel (with stainless steel pins not less than 0.3125-inch diameter) and shall be welded to both the enclosure and the door to maintain door alignment for the life of the equipment. The enclosure shall be nonventilated to minimize the entrance of airborne contamination, insects, rodents or reptiles. The protective finish shall include necessary grinding, 5-stage cleaning and

phosphatizing, two-component rust-inhibiting zinc rich epoxy primer and a Pad-Mount Green two-component polyurethane top coat finish—Munsell color 7GY 3.29/1.5 (or Optional Grey—Munsell color 5BG 7.0/0.4). The primer and top coat shall be electronically monitored during application to insure proper ratio and mixing of each component. Total average thickness of paint (after curing) shall be not less than 5 mils. The protective coating shall meet the Enclosure Coating System requirements of IEEE Standard C57.12.28 (Pad-Mounted Equipment—Enclosure Integrity). Removable lift provisions, adequate to withstand handling with normal utility equipment, shall be provided on the outside of the enclosure. Threaded openings for lift provision bolts shall be blind holes to prevent the entrance of wire or other foreign objects into the enclosure when lift provisions are removed.

Four openings for attachment of a floor support sleeve (to provide support and to enclose the bottom entrance cables) shall be provided on the bottom of the enclosure. The openings shall be 0.75-inch diameter holes and shall match the 0.75-inch diameter mounting holes in the floor support sleeve that may be installed. When specified, an 18-inch (alternate 24-inch, 30-inch, 36-inch or 42-inch) high floor support sleeve shall be supplied bolted in place with stainless-steel hardware. The floor support sleeve shall be all-welded construction utilizing 11-gauge minimum sheet steel formed to assure strength and rigidity. The protective coating of the floor support sleeve shall meet or exceed the coating requirements specified above for the enclosure.

### Bushings and Terminals

**Alternate 1:** Bushings shall be 200 ampere Elliott #1101-225B, 25 kV class (15.2 kV to ground) Air-Insulated Bushing Wells, 125 kV BIL, per IEEE Standard 386 Fig. 3 (200 A Bushing Well Interface, 8.3 kV, 15.2 kV and 21.1 kV) *for use with either 8.3/14.4 kV or 15.2/26.3 kV separable insulated connectors* (Elastimold®, Cooper Power Systems [RTE®] or other approved equal). The bushing wells shall be pressure-molded cycloaliphatic epoxy with a 0.75-inch diameter copper conductor on the “air-insulated” side that is drilled and tapped 0.375-inch – 16UNC x 1-inch deep to provide direct connection of the bus and/or live parts. Leakage distance from the apparatus connection end of the bushing well to ground shall be not less than 30 inches to assure trouble-free operation in a wet and/or contaminated environment. Integral shielding shall be provided to eliminate partial discharge caused by off-center mounting and mounting holes that may have sharp edges or burrs. Bushing wells shall mount in a 3.125-inch diameter opening and bolt in place to allow field replacement with standard tools. The bushing mounting bolts shall be self-locking stainless steel serrated-flange hex-head bolts that cut through the enclosure protective finish to ground the integral shielding of each bushing. The head of one or

**Typical Specification - Page 2 of 3**

more of the mounting bolts for each bushing shall include a 0.156-inch diameter hole to provide a connection to ground for the loadbreak insert shielding ground wire as recommended by separable insulated connector manufacturers. To assure adequate strength for apparatus support, the bushing well shall withstand a minimum cantilever loading of 600 pounds for five minutes without damage. The bushing well interface shall be free of all voids, holes and heat sinks to assure proper mating with separable insulated connectors. Each bushing well shall be tested in free air, mounted in a grounded steel plate not less than 10 inches x 10 inches, and with a bushing well plug (RTE® #IBWP225 or equal) installed in the well interface to accurately simulate operating conditions (*gas or liquid dielectric in the interface shall not be acceptable for this test*). Each bushing well shall meet the requirements for 25 kV devices in accordance with IEEE Standard 386 (latest revision), including 100 percent production testing.

**Alternate 2:** Bushings shall be 600 ampere Elliott #1201-625B2, 25 kV class (15.2 kV to ground) Air-Insulated Bushings, 125 kV BIL, per IEEE Standard 386 Fig. 10 (600 A Deadbreak Interface, 8.3 kV and 15.2 kV) for use with either 8.3/14.4 kV or 15.2/26.3 kV separable insulated connectors (Elastimold®, Cooper Power Systems [RTE®] or other approved equal). The bushings shall be pressure-molded cycloaliphatic epoxy with a 1.25-inch diameter tin-plated aluminum conductor on the "air-insulated" side that is drilled and tapped 0.625-inch – 11UNC x 1-inch deep to provide direct connection of the bus and/or live parts. Leakage distance from the apparatus connection end of the bushing to ground shall be not less than 30 inches to assure trouble-free operation in a wet and/or contaminated environment. Integral shielding shall be provided to eliminate partial discharge caused by off-center mounting and mounting holes that may have sharp edges or burrs. Bushings shall mount in a 3.125-inch diameter opening and bolt in place to allow field replacement with standard tools. The bushing mounting bolts shall be self-locking stainless steel serrated-flange hex-head bolts that cut through the enclosure protective finish to ground the integral shielding of each bushing. To assure adequate strength for apparatus support, the bushing shall withstand a minimum cantilever loading of 600 pounds for five minutes without damage. The bushing interface shall be free of all voids, holes and heat sinks to assure proper mating with separable insulated connectors. Each bushing shall be tested in free air, mounted in a grounded steel plate not less than 10 inches x 10 inches, and with an insulated protective cap (RTE® #DPC625 or equal) installed on the interface to accurately simulate operating conditions (*gas or liquid dielectric on the interface shall not be acceptable for this test*). Each bushing shall meet the requirements for 25 kV devices in accordance with the test values of IEEE Standard 386 (latest revision), including 100 percent production testing.

Terminals for the bottom entrance cables shall be provided near the bottom end of each fuse mounting and shall accept noninsulated two-hole NEMA standard connectors. The open-bottom enclosure shall provide generous space for installation of stress cones.

**Fuse Mountings**

Fuse clips and/or fuse hinges shall be keyed to prevent rotation and to maintain alignment. Positive pressure shall be assured by use of stainless steel fasteners and lock washers or compression washers at all connection points. All connections shall provide direct contact of current-carrying parts and shall not depend on current transfer through fastener thread-to-thread contact. Fuses and their blown-fuse indicators shall be visible (*when the fuse compartment door is open without removal of the clear-polycarbonate door safety barrier*) to allow easy identification of blown fuses without de-energizing or removing the fuse from service. Electrical components shall be "air-insulated" and positioned to allow visual inspection of all internal connections and components *without removing the clear-polycarbonate door safety barrier*, de-energizing or removing the equipment from service. *When Option G1 is specified*, ground studs shall be provided for each terminal at the top of the fuse mounting. *When Option G2 is specified*, ground studs shall be provided for each terminal at the bottom of the fuse mounting.

**Alternate 1:** Fuse provisions with S&C Uni-Rupter® shall accommodate S&C Fuse-Unit End Fittings Type SML-20. Fuse-Unit End Fittings, when supplied, shall accept 200 amp (max) Type SMU-20 fuse units.

**Alternate 2:** Fuse provisions *without S&C Uni-Rupter®* shall accommodate S&C Fuse-Unit End Fittings Type SML-20. Fuse-Unit End Fittings, when supplied, shall accept 200 amp (max) Type SMU-20 fuse units. (*When this alternate is selected, loadbreak operations must be accomplished with loadbreak elbows*). A Warning Sign, Elliott #7201-W2003-318, shall be provided inside the fuse compartment door to warn the operator to "Park the load side cable before installing or removing fuses." A Danger Sign, Elliott #7203-D2003-313, shall be provided in a prominent location near the fuse clips to warn the operator "Do not remove fuse under load."

**Alternate 3:** Fuse provisions with S&C Uni-Rupter® shall accommodate S&C Fuse Holder Type SML-4Z. Fuse holders, when supplied, shall accept 200 amp (max) Type SM-4 fuse refills.

**Alternate 4:** Fuse provisions *without S&C Uni-Rupter®* shall accommodate S&C Fuse Holder Type SML-4Z. Fuse holders when supplied, shall accept 200 amp (max) Type SM-4 fuse refills. (*When this alternate is selected, loadbreak operations must be accomplished with loadbreak elbows*). A Warning Sign, Elliott #7201-W2003-318, shall be provided inside the fuse compartment door to warn the operator to

## Typical Specification - Page 3 of 3

"Park the load side cable before installing or removing fuses." A Danger Sign, Elliott #7203-D2003-313, shall be provided in a prominent location near the fuse clips to warn the operator "Do not remove fuse under load."

### Bus

Bus shall be copper with all burrs and sharp corners removed prior to installation. Positive pressure shall be assured by use of stainless steel fasteners and lock washers at all connection points. All connections shall provide direct contact of current-carrying parts and shall not depend on current transfer through fastener thread-to-thread contact. Electrical components shall be "air-insulated" and positioned to allow visual inspection of all internal connections and components *without removing the clear-polycarbonate door safety barrier*, de-energizing or removing the equipment from service.

### Barriers

Phase and ground barriers shall be provided to assure correct phase-to-phase and phase-to-ground clearances for proper operation at rated voltage. These barriers shall be glass-reinforced polyester (NEMA GPO-3 class material) not less than 0.1875-inch thick.

A removable insulating barrier with a "DANGER – Keep Out! – Hazardous voltage" sign, Elliott #7203-D2003-309, shall be located inside the door(s) on the fuse compartment as recommended in Rule 381G of IEEE Standard C2 (National Electrical Safety Code). This door safety barrier shall be constructed of 0.25-inch clear polycarbonate (Lexan or equal) and shall completely close the door opening and be provided with a nonconductive safety latch requiring a positive action to remove the barrier. Handles and other hardware extending through this door safety barrier shall be nonconductive material. Handles shall be keyed to prevent rotation for secure handling. Complete visual inspection of the internal components shall be possible without removing the door safety barrier.

### Grounding Provisions

Four high-conductivity bronze eyebolt-type ground lugs, which accept #6 through #2/0 copper conductor, shall be installed on the enclosure (two on the exterior of the top and

one on each interior wall near the bottom inside sill). One 0.625-inch diameter copper grounding bar that bolts to both walls inside the enclosure shall be provided near the bottom of the door opening in a position easily accessible for attachment of grounding clamps. When grounding clamps are installed it shall be possible to close and lock the door.

### Accessory Equipment

Stainless steel parking stands shall be provided in the quantity required to allow use of feed-thru bushings, parking bushings and grounding bushings. The parking stands shall be welded in place, in a position to allow the use of hot-line tools for installation of feed-thru bushings, etc. The parking stands shall be *unpainted* (except welds shall be painted) *to provide a ground* for feed-thru bushings and other devices that may be placed into the parking stands. *Keyed retainers* shall be welded above each parking stand *to prevent slipping or accidental removal* of portable devices such as feed-thru bushings, etc.

An anodized aluminum nameplate shall be installed inside the compartment door. It shall be located at the top corner farthest from the enclosure when the door is open. The nameplate will provide Type of Equipment, Model Number, Amps Continuous, kV Maximum, BIL, Serial Number, Date Manufactured and Weight of Equipment.

The enclosure shall be labeled in near proximity of the locking provisions with a pressure-sensitive vinyl label using letters not less than 0.375-inch nor more than 0.625-inch high. The label shall indicate the type of equipment behind the access (switch, fuses, bus, etc.).

### Packaging

Each fuse-gear shall be bolted to a solid-top wood pallet to prevent hidden damage. The equipment shall be wrapped with 0.125-inch thick polyethylene foam or other suitable material to minimize damage to the finish during shipment.

### Drawings

When specified, drawings shall be furnished for each fuse-gear that include:

- 1) enclosure dimensions and location of components.
- 2) proposed labels and location of labels.



**25-kV Wall/Base-Mount Fuse-Gear  
200 Amp S&C SMU-20 and SM-4 Fuses**  
Three Phase – Indoor/Outdoor

Bulletin  
**550-214**  
Page 12 2007

**If you do not find the design  
you need  
PLEASE CONTACT  
our REPRESENTATIVE or the FACTORY**